

AMETEK Model 5000 Moisture Analyzer

The versatile AMETEK Model 5000 is a highly sensitive moisture analyzer for process applications where the continuous, reliable measurement of moisture in vapors and gases is required.

The Model 5000 analyzer measures moisture on-line by monitoring the vibrational frequency change of a hygroscopically sensitized quartz crystal that is exposed alternately to wet sample and dry reference gas for 30 second periods. The reference gas is sample gas passed through a molecular sieve dryer to remove virtually all its moisture content.

Won't Die in Place

Many moisture analyzers are susceptible to attack by the process stream. Unsaturated hydrocarbons, compressor oils, oxygen, carbon dioxide, and others can permanently damage or destroy trace moisture sensors.

Even worse, a fouled sensor can become completely unresponsive to moisture yet continue to give an output. This "dying-in-place" behavior leaves your process unmonitored.

Bullet-Proof Performance

The Model 5000 gives you "bullet-proof" performance in critical moisture applications. Unique differential measurement principle, combined with continuous diagnostics, ensures reliable performance.

Field Unit

The field unit is explosion-proof, in accordance with CENELEC Zone 1 and NEC Class I, Groups B, C, D, Division 1 requirements. It contains a sample cell, switching valves and associated electronic circuits mounted internally and a flowmeter, flow control valves and back pressure regulator mounted externally.

Controller

The controller is designed for NEC Class I, Division 2, Groups A, B, C, D areas. A microprocessor provides control, data processing, and digital display. Outputs include RS485 bidirectional serial data, two fully configurable 4-to-20mA



analog signals, and three configurable alarms. It can be separated from the field unit by up to 2000 ft. (600 m).

Dryer

The external dryer supplies the analyzer with reference gas by using a molecular sieve to dry the actual process gas.

BENEFITS

- **Reliable performance**—The unique quartz crystal moisture detection technique has consistently proven long-term reliability and accuracy over decades in hundreds of applications.
- **Internal verification...on your process gas**—A factory-calibrated, built-in moisture generator is standard. The generator works on automatic or manual command to add a known amount of moisture to dried process gas. This periodic check assures proper system and sensor operation.
- **Fast response**—The Model 5000 responds within seconds when moisture levels increase. For a sudden drop from 1000 to 10 ppm, the analyzer reaches 90% of the steady-state reading within 1 minute.
- **Few interferences**—The Model 5000 is specific to water in almost all applications. Hydrogen and oxygen do not interfere.
- **No process temperature or pressure compensation required**—Sample gas is measured at known temperature and pressure. Thus, no correction is needed for normal variations in process temperature and pressure.
- **Wide range moisture**—The Model 5000 is factory calibrated from 0 to 1000 ppmv moisture. It indicates at levels to 9999 ppmv, allowing you to monitor moisture from startup through normal process operation.

TYPICAL APPLICATIONS

Catalytic Reforming

Problem—Proper moisture balance in feedstocks and hydrogen recycle streams must be maintained to optimize product yield and catalyst life. Measurement reliability is greatly complicated by the presence of compressor oils and high boiling point hydrocarbons in the stream. The reformer process typically requires accurate and rapid results despite variations in moisture content from 10 to 25 ppm.

Solution and Results—The Model 5000's accuracy, reliability, and fast response are not affected by normal reformer contaminants such as compressor oils and high boiling point hydrocarbons. The onboard moisture generator verifies measurement accuracy for optimum product yield. Readings are absolute and provable, not just trends.

Moisture in Olefins

Problem - Ethylene polymerization catalysts are extremely sensitive to trace water. Water decreases catalyst activity and may turn the catalyst black, leading to discoloration of the virgin polymer. Accurate, reliable, and rapid sub-1 ppm moisture analysis is required.

Solution and Results—The Model 5000's quartz crystal sensor does not promote unsaturated hydrocarbon polymerization, a common problem with electrolytic moisture sensors. Exceptional response speed and precision in the sub-1 ppm moisture range ensures consistently high product quality. The onboard moisture generator verifies this measurement accuracy.

Moisture in Natural Gas

Problem—Excess moisture in natural gas causes serious problems, from pipeline, storage tank, and equipment corrosion to gas hydrate formation. Measuring moisture in natural gas is not a difficult application, but reliably measuring it on a continuous basis is. Glycol carryover and entrained compressor oils can quickly damage insitu sensors.

Solution and Results—The extended cell life mode minimizes sensor exposure to contaminants and strips volatile contaminants. The on-board moisture generator permits you to quickly and easily verify and adjust calibration.

OTHER APPLICATIONS

The 5000 provides similar solutions to problems in a variety of other applications, including:

- **Petroleum Refining**—Reforming; Alkylation; LPG; Light Hydrocarbons; Isomerization
- **Natural Gas**—Cryogenic extraction; Transmission stations; Storage/Distribution; LNG; Production
- **Petrochemicals**—Cracked gas; Propylene; Butadiene; Ethylene
- **Chemicals**—Fluorocarbon gases; Vinyl chloride; Vinyl fluoride; Refrigerants; Reactor gas blankets; Methyl Chloride
- **Enhanced Oil Recovery**—CO₂ Pipelines
- **Electronics**—Doping gases; Dielectric gases; Soldering furnace atmospheres; Brazing furnace atmospheres; Blanketing gases
- **Metals**—Annealing furnace atmospheres

INTERNAL MOISTURE GENERATOR

Key Benefits

- **Confidence in analyzer accuracy and reliability, using actual sample gas**
- **Easy to use—touch pad operation, no connections to make, fast equilibration**

Principle of Operation

The moisture generator (see diagram) adds a known amount of moisture to dried process gas. It consists of a temperature-controlled water reservoir and permeation tube. Moisture concentration in the calibration gas is controlled by temperature, gas flow rate, and tubing dimensions and permeability. The tubing is designed to allow moisture permeation at low parts-per-million levels. Constant gas temperature is maintained by proportional temperature control. A regulator controls gas flow. Output is typically 3 ppm or 20 ppm, depending on the application.

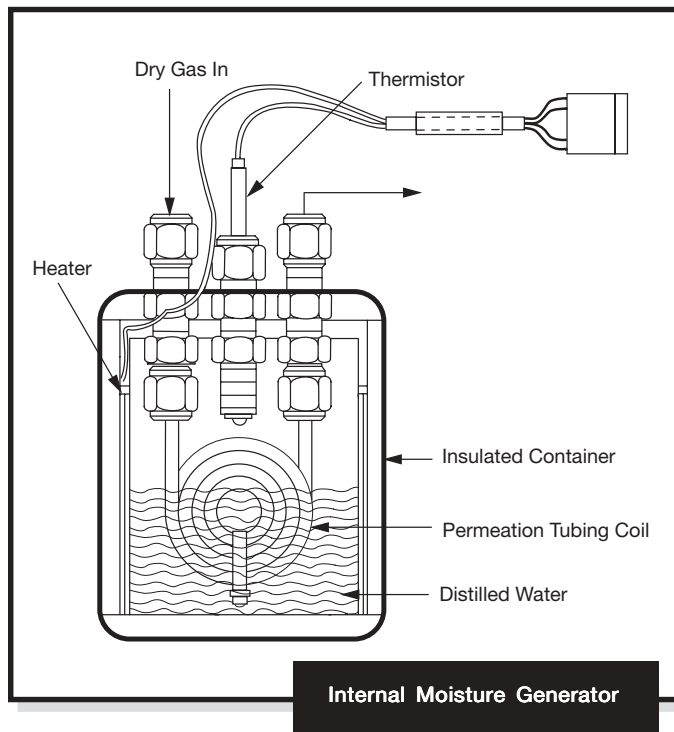

SYSTEM OPTIONS

Extended Cell Life (Asymmetric Cycle)

This option protects the detector in applications where the sample contains liquid contaminants such as glycols, compressor oils, or high boiling point hydrocarbons.

It works by cycling process gas through the detector for 30 seconds, then switching to cleaned, dried reference gas for

9.5 minutes. This minimizes detector exposure to contaminants and strips volatile contaminants from the detector during the reference cycle.

Acid Gas

This option permits reliable measurement in streams containing up to 30 percent H₂S. It includes a treated cell and activated charcoal scrubber to maintain a corrosion-free environment within the analyzer.

ACCESSORIES FOR INCREASED VERSATILITY

Sample Systems

The best way to get the full advantages of the exceptional performance of the Model 5000 is to use a well-designed sample system. AMETEK's Model 561 Series single and multi-point sample systems are engineered to deliver:

- **Increased measurement accuracy and reliability**
- **Single-supplier convenience and accountability**
- **Automatic multi-stream monitoring with a single analyzer**
- **Lower total installation costs**

Filter, In-line or Bypass

This filter removes particulate from gas or liquid sample streams and small amounts of oil or other condensables from gas streams.

Contaminant Trap

This activated charcoal trap removes condensable hydrocarbons from reference streams. It is supplied with the Extended Cell Life Option.

Superactivated Dryer

To obtain optimum accuracy at moisture levels of 5 ppmv or less, this superactivated dryer supplements the supplied dryer.

Pressure Reducer

Required when sample sources are at pressures of over 100 psi (700 kPa) gauge. Maximum input pressure is 3000 psi (20,700 kPa) gauge.

Heated Pressure Reducer

Designed to prevent condensation of gases upon pressure reduction, or to vaporize liquefied gas streams with boiling points not exceeding 140°F (40°C). Maximum input pressure is 3000 psi (20,700 kPa) gauge. Suitable for NEC Class I, Division 1, Groups B, C, D and CENELEC IIC T3 areas.

PERFORMANCE SPECIFICATIONS

Ranges: Calibrated 0 to 1000 ppm by volume (ppmv). Display continues to provide trend information above 1000 ppmv.

Output capability in lb./mmscf and dewpoint (requires sample line pressure as analog input; single point systems only.)

Outputs: 80-character vacuum fluorescent display. Two 4-to-20 mA analog signals with completely user-settable span; one analog output is autoranging. RS485 bidirectional serial port.

Alarms (3): System Alarm; Concentration Alert; Range or Calibration Alert

Sensitivity: 0.1 ppmv or 0.5% of reading, whichever is greater

Accuracy: 0 to 20 ppm: 1 ppm; greater than 20 ppm: 5% of reading

Reproducibility: 0.2 ppmv or 1% of reading, whichever is greater

Operating Pressure: 15 psi (103 kPa) gauge

Allowable Inlet Pressure: 30 to 100 psi (207 to 690 kPa) gauge

Sample Gas Temperature: 32° to 212°F (0° to 100°C)

Gas Flow Requirements: 750 mL/min @ 15 psi (103 kPa)

Utility Requirements: All systems are available with choice of nominal AC voltages:

100 ±10%, 50/60 Hz

115 ±10%, 50/60 Hz

230 ±10%, 50/60 Hz

Field Unit: 175 W

5000 Controller: 95-230 V ±10%, 47-63 Hz, 75 W

Maximum Separation: 2000 ft. (600 m) between field unit and controller

Ambient Temperature Limits:

Field Unit: -4° to 122°F (-20° to 50°C) without heat; -40° to 122°F (-40° to 50°C) with optional electric heat

5000 Controller: 14° to 122°F (-10° to 50°C)

Moisture Generator Value: Exact values stated with analyzer

Nominal: 20 ppmv

Low Option: 3 ppmv

APPROVALS AND CERTIFICATIONS

UL/CSA General Safety Requirements

Field Unit: UL Class I, Div 1, Groups B, C, D (optional: CSA Special Acceptance); CENELEC II 2 G EEx d IIC T6

Controller: UL/CSA Class I, Div 2, Groups A, B, C, D T4 (Div 1/Zone 1 optional)

Complies with all relevant European directives

Russian Gosstandart Pattern Approval

Russian Ex Proof Certification

The AMETEK Model 5000 is one of a family of exceptional moisture analyzers from AMETEK, a leader in process instruments. Contact the factory or your local representative for more information.

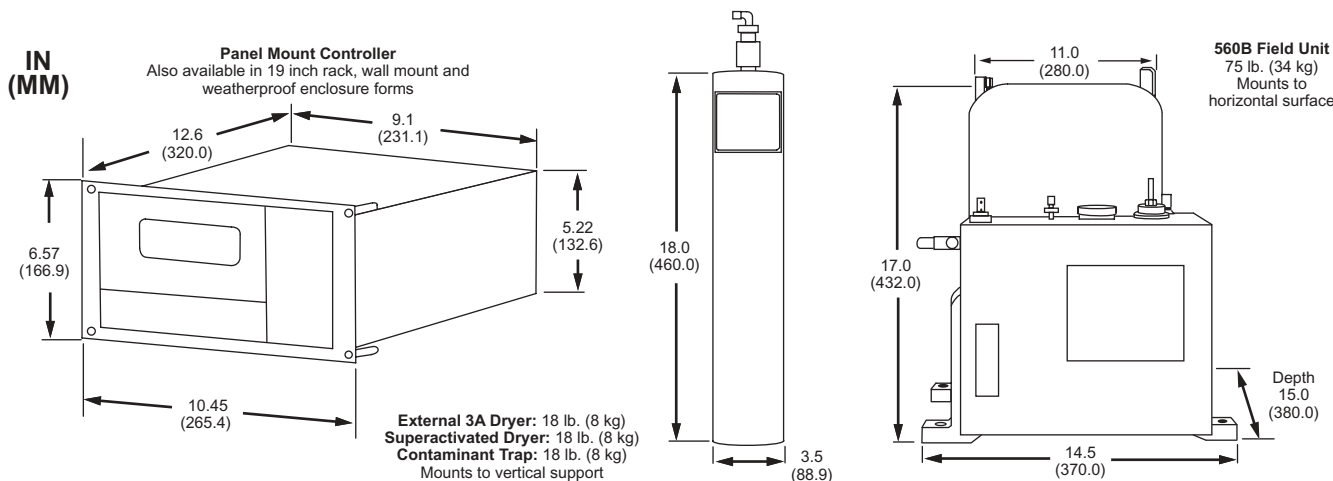

One of a family of innovative process analyzer solutions from AMETEK Process Instruments. Specifications subject to change without notice.

AMETEK®
PROCESS INSTRUMENTS

CANADA
2876 Sunridge Way N.E.
Calgary, AB T1Y 7H9
Ph. 403-235-8400
Fax 403-248-3550

USA - Delaware
455 Corporate Blvd.
Newark, DE 19702
Ph. 302-456-4400
Fax 302-456-4444

USA - Pittsburgh
150 Freeport Road
Pittsburgh, PA 15238
Ph. 412-828-9040
Fax 412-826-0399

USA - Texas
9750 Whithorn Drive
Houston, TX 77095
Ph. 281-463-2820
Fax 281-463-2701

CHINA
Ph. 86 21 6426 7049
Fax 86 21 6426 7054

FRANCE
Ph. 33 1 30 68 69 20
Fax 33 1 30 68 69 29

GERMANY
Ph. 49 21 59 91 36 0
Fax 49 21 59 91 36 80

MIDDLE EAST - Dubai
Ph. 971-4-881 2052
Fax 971-4-881 2053



www.ametekpi.com

© 2002, by AMETEK, Inc. All rights reserved.
5000 Anlzr (10/08/02)