

The Thermox PreMix 2000 analyzer accurately and continuously measures the proportions of oxygen and fuel in pre-mix gases, operating in either excess fuel or excess air conditions. The analyzer is fed a small sample of the air/fuel mixture, burns it and then measures the results.

The PreMix 2000 uses the Series 2000 Control Unit. This state of the art microprocessor control unit provides software-selectable calibration options, and extensive analog and digital I/O capabilities, including a bi-directional RS-485 communications port. It also employs a modular design that makes adding future upgrades or servicing easy.

FEATURES/BENEFITS

- Measure air/fuel ratio in open-flame applications where flue gas measurements are not practical.
- Measurement and display options include excess oxygen, excess fuel, combined excess oxygen to excess fuel range, fuel/oxides, oxides/fuel, combustibles, time and date, cell temperature, user programmable text, thermocouple mV, or cell mV.
- Operates under either excess air (lean) or excess fuel (rich) conditions.

THE COMPANY

AMETEK, manufacturer of the Thermox product line, is a leading global producer of precision instruments, electro-mechanical devices, and engineered industrial materials. The Thermox product line is backed by over 30 years experience, even in the most difficult applications. Thermox pioneered the industrial use of zirconium oxide to measure oxygen in 1967, and is supported by more than 80 sales representative and distributor organizations worldwide. The Thermox facility of AMETEK is ISO 9001 registered.



OPERATION

Most of the sample gas entering the analyzer passes through the bypass flow meter, which ensures a fast response and keeps the sample inlet purged of dead volume. A small portion of the sample flows through the sample flow meter and flashback arrestor to the furnace. An igniter at the inlet of the furnace enables the fuel mixture to burn. The products of combustion then flow past the zirconium oxide cell, where they are measured.

APPLICATIONS

- Glass forehearth
- Air/fuel mixtures
- Glass fiber apparatus
- Open flame brazing and soldering
- Tempering furnaces
- Gas generators
- Metals and metal forming

CONTROL UNIT

Display:

Four line x 20 character vacuum fluorescent. Displays combinations of excess oxygen, excess fuel, combined oxygen to excess fuel range, fuel/oxides, oxides/fuel, combustibles, time and date, cell temperature, user programmable text, thermocouple mV, or cell mV. Password protection and context-sensitive help are provided.

Recorder Output:

Two isolated linear current outputs. Select excess oxygen, excess fuel, combined excess oxygen to excess fuel range, combustibles, fuel/oxides, oxides/fuel, cell temperature, thermocouple mV or cell mV. Each output can be 4-20 mA, 0-20 mA, 20-4 mA or 20-0 mA and is fully scalable. Hold or track during calibration and select degree of damping. Maximum load 1200 ohms.

Alarms:

Two independent alarms, each high or low selectable. One alarm can be allocated to sensor readings, calibrate or verify. Set relays to energize or de-energize on alarm. Contact rating max. 30VA, 30V max. non-inductive load.

Diagnostics:

Watchdog timer and service alarms. System test for A/D, RAM, EEPROM, and keypad. Display line 4 reserved for full text error and diagnostic messages. Twenty-entry event log.

Communications:

RS-485, 2-way addressable

Environment:

Ambient Temp: 14 to 122° F (-10 to 50° C)
Relative Humidity: 10% to 90%, non-condensing

System Compliance:

- EMC Directive 89/336/EEC
- Immunity Standard, EN 50082-2, Heavy Industrial
- Emissions Standard, EN 55011, Equipment Class: Industrial, Scientific, and Medical
- Low Voltage Directive 73/23/EEC
- Safety requirement for electrical equipment for measurement, control, and laboratory use, EN 61010-1 (IEC1010-1)

Enclosure:

Choice of general purpose wall mount, general purpose 19" rack mount, general purpose panel mount, weatherproof NEMA 4 (IP 56) wall/panel mount, and stainless steel NEMA 4X (IP 56) weatherproof wall/panel mount. All are UL Listed for NEC Class I, Division 2 areas. Purged and explosion-proof versions also available.

Calibration:

Calibrate or verify calibration. Store last calibration and verification data. Selectable calibration gas run time and process recovery time.

Power Requirements:

Nominal 95-230 VAC, ± 10%, 47-63 Hz.
Power dissipation: 75 VA max.

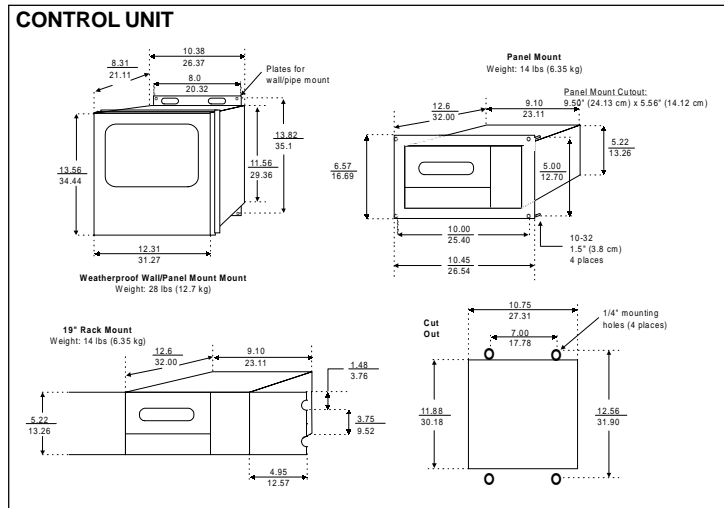
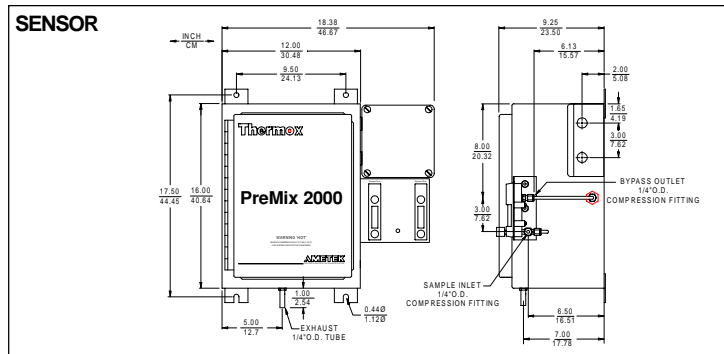

SENSOR

Range: All or selected portions of the range from 100% to 0.1% excess oxygen and 0.1% to 50% Excess Fuel

Accuracy: ± 2% of measured value or ±0.1% O₂, whichever is greater
± 5% of measured value or .25% excess fuel, whichever is greater*.

Repeatability: ± 0.2% of measured value

Ambient Temperature: -5 to 160° F (-20 to 71° C)

Sample Flow Rate: 0.5 l/min. (1 scfh),
Bypass flow rate - 50 l/min. max. (106 scfh)

Maximum Sample Pressure: 10 psig

Power: 115 VAC ± 10%, 50/60 Hz., 1200 VA max.,
230 VAC ± 10%, 50/60 Hz., 1780 VA max.

Calibration Gas Flow Rate: 10 psig, 2.1 to 4.2 scfh (@ 0.70 kg/cm², 1.0 to 2.0 l/min.)

Excess Oxygen Calibration Gases:

- O₂ Span Gas: 20.9% (air) or from 1.0 to 100% O₂, balance N₂
- O₂ Zero Gas: 2% or from 0.1% to 10% O₂, balance N₂

Excess Fuel Calibration Gases:

- CO₂/CO Span: 40 to 60% of recorder output span
- CO₂/CO Zero: 5 to 10% of recorder output span

* Specifications based on 0-15% range, Natural Gas

Specifications contained herein are subject to change without notice. Since it is impossible to anticipate or control the many different conditions under which this information or our products may be used, AMETEK cannot guarantee the applicability and accuracy of the information or the suitability of our products in any given situation. Printed in the U.S.A. 1999, by AMETEK, Inc.