

# THEERMOX<sup>®</sup>



***THE RIGHT ANALYZER FOR YOUR APPLICATION***





AMETEK, INC. IS A LEADING GLOBAL COMPANY ENGAGED IN THE DESIGN, MANUFACTURE AND SALE OF ELECTRONIC INSTRUMENTS AND ELECTROMECHANICAL DEVICES WITH MORE THAN 60 MANUFACTURING FACILITIES AND MORE THAN 60 SALES AND SERVICE CENTERS IN THE UNITED STATES AND OVER 30 OTHER COUNTRIES AROUND THE WORLD. AMETEK PRODUCTS ARE USED BY INDUSTRIES SUCH AS AEROSPACE, AUTOMOTIVE, FLOOR CARE, BUSINESS MACHINES, MEDICAL, COMPUTER MARKETS, AS WELL AS PROCESS INDUSTRIES WORLDWIDE.

## THERMOX®

### THE RIGHT ANALYZER FOR YOUR APPLICATION

The Thermox product line offers the greatest selection of flue gas analyzers in the industry for measuring oxygen, combustibles, methane, and fuel-rich atmospheres. Our commitment is to provide the right analyzer for every application to ensure the highest levels of efficiency, cost savings, and safety for our customers.

### NO<sub>x</sub> REDUCTION AND FLUE GAS MEASUREMENT

Modern combustion burner systems redistribute primary air to secondary air registers for the purpose of staging combustion to reduce thermal NO<sub>x</sub> generation. The mechanical redistribution of excess air drives combustion closer to stoichiometric conditions resulting in a reduction in excess air, associated heat loss, and an increase in background combustibles levels.

Thermox improves your modern combustion process by providing a combined oxygen and combustibles, or oxygen, combustibles and methane measurement that facilitates safety in combustion control and efficiency strategies. Once background combustibles levels are determined, additional reductions in excess air can be safely achieved to minimize NO<sub>x</sub> generation and increase combustion efficiency.

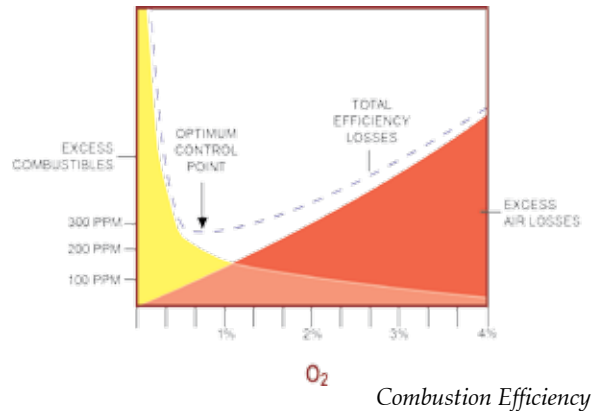

### THERMOX SITE SURVEY ANALYSIS

Thermox can demonstrate the fuel savings and emissions reduction gained by measuring oxygen and combustibles by performing a site survey analysis using a portable analyzer. Our service personnel along with your operational assistance will perform air-to-fuel ratio step testing to determine the safest, lowest excess O<sub>2</sub> set point. Combustion efficiency gain and NO<sub>x</sub> emissions reduction will be measured and recorded. A report will detail opportunities to increase your combustion efficiency and maximize fuel savings. In most cases, a pay-back period of less than two months can be demonstrated for the combustibles option. At the same time we can also evaluate the condition of your existing Thermox analyzers and provide maintenance, retrofit and/or new analyzer purchase suggestions.

Contact Thermox Service or Sales to arrange a site survey analysis of your facility today by calling (412) 828-9040.

## **IQ™ AND SERIES 2000 HOST** **ELIMINATES NEED FOR CONTROL UNIT**

The IQ sensor incorporates the necessary intelligence for proper operation. The electronics contained in the sensor include all Series 2000 features: auto calibration, analog output, alarm, self-diagnostics, and network communications. A system trouble alarm signal alerts the user if the self-diagnostics determines a problem requiring service attention.

The IQ or smart sensor line provides local and field communications. The new design allows access to process variable and diagnostic data previously inaccessible using conventional analog outputs. IQ analyzers are available with HART or RS-485 AMETEK protocol communications options. User interface with the IQ sensor is achieved through a HART-compatible device, IQ Link Terminal, Series 2000 Host or web-enabled RS247 gateway system.



*Handheld and Wall Mount IQ Links*



*Series 2000 Host*

### **REMOTE WEB-ENABLED ACCESS SYSTEM (RS247)**

The RS247 (24 hours/day, 7 days/week) gateway converts the RS-485 AMETEK protocol to an open system HSE (High-Speed Ethernet) protocol. The RS247 gateway can be set up on your Local Area Network and/or Wide Area Network allowing plant- or company-wide access to all of your Thermox IQ and Series 2000-based analyzers. Or, you can choose to access the RS247 gateway system using the World Wide Web through your IT system. The system can send an E-mail to a primary, secondary and tertiary list when a system alarm or event occurs. It also provides trending, service and calibration history.



*RS247 Gateway*

### **IQ LINKS**

Handheld or dedicated wall mount IQ Link terminals are also available. The IQ Link provides a local interface using RS-232 communications to set up and display system parameters, initiate calibrations, system tests, and troubleshooting. With the handheld IQ Link you can disconnect and reconnect to other IQ analyzers. The handheld and dedicated wall mount unit also work in cooperation with the Series 2000 Host or RS247 gateway system capable of linking up to 32 analyzers via an RS-485 bus.

### **SERIES 2000 HOST**

The Series 2000 Host provides an interface to multiple Thermox IQ and/or Series 2000-based analyzers. Up to 32 analyzers can be connected to a single Host using RS-485 with AMETEK protocol. The Host can generate up to four averaged %O<sub>2</sub> outputs or high/low-selects for a group of connected analyzers, or up to four high-selects for combustibles and/or CO.

.....  
THERMOX IQ AND SERIES 2000-BASED ANALYZERS ARE EMC COMPLIANT TO 89/336/EEC AND LOW VOLTAGE SAFETY COMPLIANT TO 73/23/EEC. THEY ARE ALSO UL AND C-UL LISTED.

# IQ™ AND SERIES 2000

## POWERFUL FEATURES FOR YOUR APPLICATION

### RELIABILITY

High quality components are used throughout to ensure reliable performance, including an internationally approved universal input power supply and two independent watchdog timers that monitor system operations. Input and output electronic transient protectors are standard.

### AUTOMATIC TIMED CALIBRATION

The built-in real time clock allows automatic timed calibrations when combined with the optional remote calibration unit and calibration module. This function not only saves time and labor but is also often a requirement for emissions compliance.

### MODULAR DESIGN FOR FLEXIBILITY AND SERVICEABILITY

The IQ and Series 2000-based analyzers are built from modules designed for serviceability. This approach makes it easy to upgrade or add options such as automatic calibration or combustibles and/or methane measurements.

### CHOICE OF MEASUREMENTS

You can monitor oxygen only, oxygen and combustibles, oxygen and methane (IQ series only), or oxygen, combustibles, and methane from a single analyzer. With the Excess Fuel option, the Series 2000 control unit can measure fuel-rich/reducing atmospheres (see the Excess Fuel option).

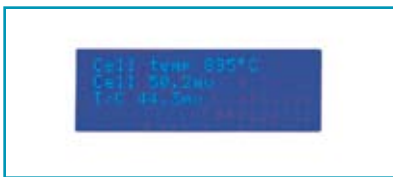

### O<sub>2</sub> CELL LIFETIME EXTENDER

Natural aging, combined with process conditions, may cause the performance of zirconium oxide to degrade over time. Some analyzers simply predict the approximate lifetime remaining after each calibration. Our analyzers go further by actually extending the cell life through precise control of cell operating parameters.

### EASE OF USE

The IQ and Series 2000 have an informative full-text display and intuitive user interface. The four-line display has 20 characters per line with line 4 reserved for automatically detected error and diagnostic information.

### SOFTWARE DIAGNOSTICS

A system test, accessible from the Setup menu, checks the A/D, RAM, EEPROM and keypad.

### 3-IN-1 DISPLAY

With the WDG-IVCM analyzer, you can display oxygen, combustibles and methane together.

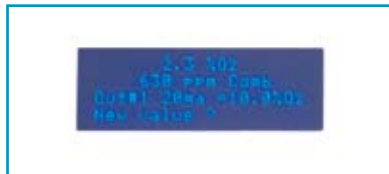

### ANALOG OUTPUT

Independent current outputs for oxygen, combustibles, and/or the methane option are available. You can assign oxygen, cell temperature, thermocouple mV, cell mV, combustibles or methane to each current output and choose hold or track during calibration. The output range is software scalable, and you can easily select between 4-20 mA, 0-20 mA, 20-4 mA or 20-0 mA. The degree of damping for each output is programmable.

### ALARMS

Independent oxygen alarms are each high or low selectable. One alarm can be set to show when the unit is in calibrate or verify mode. Two additional alarms are provided with the combustibles and/or methane option. Relays can be set to energize or de-energize on alarm. Independent service alarms are also included. Dry contacts are provided for each alarm.

### CALIBRATION AND VERIFICATION

Perform a full calibration or a verification that checks the calibration without making changes

- Select the process recovery time and the calibration gas run time.
- View the previous calibration and verification data.

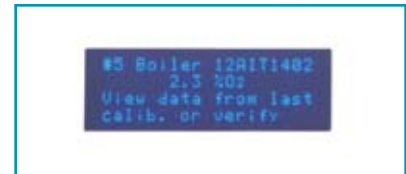

### ADDITIONAL FEATURES

- Password protection.
- Programmable process pressure compensation.
- User text allows a personalized identification text string to be placed on lines 1, 2 or 3.

# IQ™ AND SERIES 2000

## FLEXIBILITY TO SUIT YOUR NEEDS

The choice of smart sensors or discrete sensor and control unit combinations offers flexibility to suit application and site requirements. For installations where a separate control unit is preferred, the Series 2000 can be located up to 1000 ft. (304 m) from the sensor.

The Series 2000 Control Unit is offered in several packaging options. For many flue gas applications, the control unit is located outdoors or in an area that can be exposed to water. For these environments, the weatherproof NEMA 4 (IP 56) or weatherproof stainless steel NEMA 4X (IP 56) option is available. Both are of a rugged, welded construction designed for long life in heavy industrial service, and can be either wall- or panel-mounted. Hazardous area enclosures are also available, including ATEX and NEC approved versions.

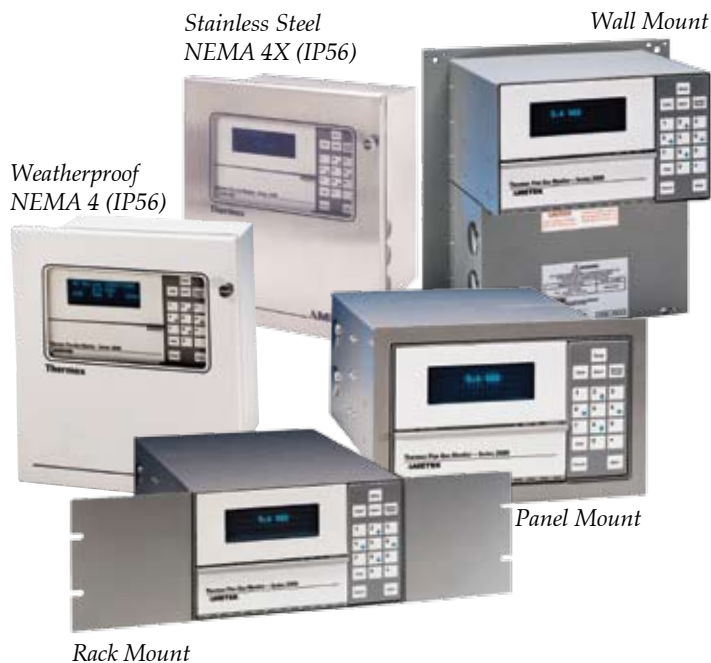

## ANALYZER SELECTION

### WHICH THERMOX ANALYZER IS RIGHT FOR YOUR APPLICATION?

With the great variety of flue gas applications, such as boilers, furnaces, kilns, process heaters and incinerators, no single analyzer design can be suitable for all.

Thermax has developed four types of analyzers to meet your application needs.

#### CLOSE-COUPLED EXTRACTIVE

- WDG-IV<sup>3</sup>
- WDG-IVC<sup>1</sup>
- WDG-IVCM<sup>1,2</sup>
- WDG IV/IQ
- WDG IVC/IQ<sup>1</sup>
- WDG IVM/IQ<sup>2</sup>
- WDG IVCM/IQ<sup>1,2</sup>
- WDG-IVC / 0-500 PPM<sup>1</sup>
- WDG IVC/IQ / 0-500 PPM<sup>1</sup>
- WDG IVCM/IQ / 0-500 PPM<sup>1,2</sup>

#### CONVECTIVE

- WDG-HPII<sup>3</sup>
- WDG-HPIIC<sup>1</sup>
- WDG HPII/IQ
- WDG HPIIC/IQ<sup>1</sup>
- WDG HPIIM/IQ<sup>2</sup>
- WDG HPIICM/IQ<sup>1,2</sup>

#### INSITU

- WDG-INSITU
- WDG INSITU/IQ
- WDG 210/INSITU

#### EXTRACTIVE

- CEM/O<sub>2</sub><sup>3</sup>
- CEM O<sub>2</sub>/IQ
- CEM/HUMOX

#### AVAILABLE OPTIONS:

- <sup>1</sup> COMBUSTIBLES DETECTOR
- <sup>2</sup> METHANE DETECTOR
- <sup>3</sup> EXCESS FUEL OPTION

.....

CUSTOM PACKAGING IS ALWAYS AN OPTION. CALL US IF YOU HAVE SPECIAL NEEDS FOR YOUR APPLICATION. OUR APPLICATIONS SPECIALISTS WILL BE PLEASED TO DISCUSS THE OPTIMUM ANALYZER CONFIGURATION TO SUIT YOUR PROCESS.

# WDG-IV, WDG-IVC AND WDG-IVCM

## CLOSE-COUPLED EXTRACTIVE FLUE GAS ANALYZERS

FOR OXYGEN — OXYGEN AND COMBUSTIBLES — OXYGEN, COMBUSTIBLES AND METHANE



WDG-IV Series 2000 with Standard Liftoff Enclosure

Designed for fast response in a wide range of flue gas applications, this analyzer mounts directly on the combustion process to provide continuous measurement of oxygen (WDG-IV) or oxygen and combustibles (WDG-IVC). It is suitable for gas streams up to 1300°F (704°C) with standard 316 SS probes. Flue gas temperatures up to 3000°F (1648°C) can be measured using optional high temperature probes. For corrosive gas streams, sample wetted parts in Hastelloy® or Inconel® are available. The analyzer is provided in a range of mounting styles. For hazardous area locations, purged or explosion-proof versions are available.

### APPLICATIONS

- Boilers
- Ceramic kilns
- Gas and light oil-fired boilers
- Furnaces
- Incinerators
- Process heaters
- Reformers

For more detailed information, ask for bulletin —

- P-260 (WDG-IV)
- P-220 (WDG-IVC)
- P-510 (WDG IV/IQ)
- P-570 (WDG-IVC / 0 to 500 PPM)
- P-600 (WDG IVC/IQ) or
- P-610 (WDG IVC/IQ / 0 to 500 PPM)

### IV SERIES SENSOR DETAILS

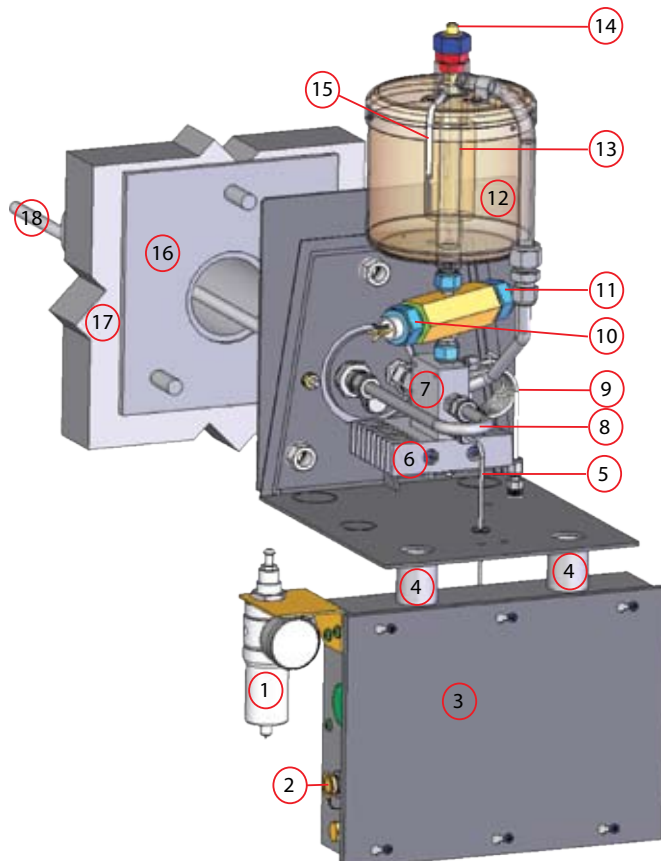

- 1 ASPIRATOR AIR REGULATOR & GAUGE
- 2 PLUG-IN CONNECTOR (IQ ONLY)
- 3 TERMINAL BOX
- 4 INTERNAL WIRE CONDUITS
- 5 ASPIRATOR AIR LINE
- 6 HEATER BLOCK ASSEMBLY
- 7 ASPIRATOR BLOCK
- 8 INLET HOOK
- 9 CALIBRATION GAS LINE
- 10 COMBUSTIBLES DETECTOR (OPTION)
- 11 METHANE DETECTOR (OPTION)
- 12 FURNACE (CELL HEATER)
- 13 CELL HOUSING
- 14 OXYGEN CELL (ZIRCONIA)
- 15 THERMOCOUPLE
- 16 MOUNTING PLATE
- 17 PROCESS WALL
- 18 PROBE

The WDG-IVCM analyzer measures oxygen, combustibles and methane in natural gas-fired applications. It is ideal for gas-fired power boilers or for those using natural gas during start-up and shutdown. With this analyzer, you can monitor oxygen and combustibles for maximum fuel efficiency. In addition, the methane detector can be used for purge and lightoff cycles during start-up and shutdown.

- .....
- For more detailed information, ask for bulletin —
- P-230 (WDG IVCM)
  - P-600 (WDG IVCM/IQ or WDG IVM/IQ) or
  - P-610 (WDG IVCM/IQ / 0 to 500 PPM)



WDG-IV Series 2000 with Optional Hinged Enclosure

### UNIQUE CLOSE-COUPLED EXTRACTIVE TECHNIQUE

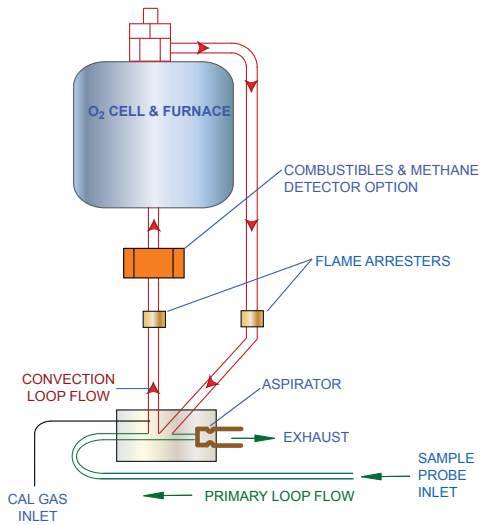

Case heaters maintain the internal sample wetted parts above the acid dew point of the flue gas. A sample is drawn into the analyzer by means of an air or nitrogen operated aspirator and returned immediately to the process. This is the primary or fast loop. A convection loop containing the zirconium oxide oxygen cell is mounted at right angles to the primary loop. Due to the natural convection generated by the temperature difference between the cell location (695°C) and the return leg (approximately 215°C), a portion of the sample rises into the convection loop, past the detector(s) and oxygen cell then back to the primary loop. The controlled conditions of the convection loop are ideally suited to catalytic combustibles and methane detectors which benefit from a constant temperature and constant flow environment.

### CONVECTION LOOP OPERATION

Process gas is drawn into the analyzer's primary sample loop by an aspirator and returns to process. Gas enters the split flow block that is separated by a baffle and contacts the catalytic combustibles and methane detector. It then passes to the zirconium oxide cell, where the oxygen concentration is measured, before returning to the main sample loop and then back to the process.

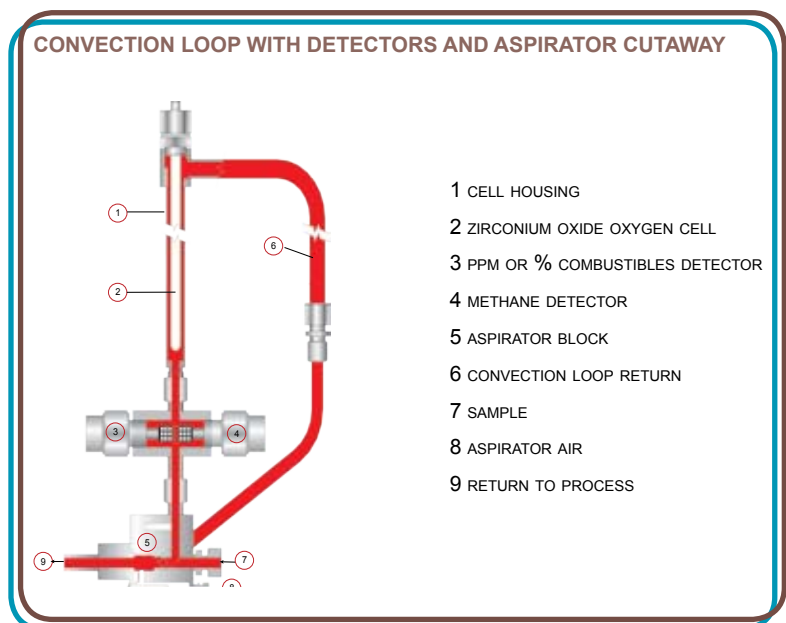

# WDG-HPII AND WDG-HPIIC

## CONVECTIVE FLUE GAS ANALYZERS



WDG-HPII with Standard Liftoff Enclosure

Designed for applications with high particulate levels in the gas stream, the analyzer mounts directly on the combustion process to provide continuous measurement of oxygen (WDG-HPII) or oxygen and combustibles (WDG-HPIIC). This analyzer is suitable for gas streams up to 1300°F (704°C) using the standard 316SS probe/filter assembly. Flue gas temperatures up to 2800°F (1537°C) can be measured using optional high temperature probes. For corrosive gas streams, sample wetted parts in Hastelloy® or Inconel® are available. The analyzers can be provided in a range of mounting styles. For hazardous area locations, purged or explosion proof versions are available.

For more detailed information, ask for bulletin —

- P-210 (WDG-HPII)
- P-270 (WDG-HPIIC)
- P-530 (WDG HPII/IQ) or
- P-590 (WDG HPIIC/IQ)

A methane option is available using the split flow block.

- P-590 (WDG HPIIM/IQ or WDG HPIICM/IQ).

### APPLICATIONS

#### INCINERATORS

- Garbage
- Hazardous
- Liquids
- Spent acid
- Sludge
- Tail gas

#### BOILERS

- Bagasse
- Coal
- Heavy oil
- Wood

#### KILNS

- Cement
- Lime
- Rotary

#### FURNACES

- Annealing
- Blast furnace
- Carbon
- Coke oven
- Galvanizing
- Melting
- Reforming
- Reheat
- Roasting
- Sintering
- Wax burnout

Case heaters maintain the internal sample wetted parts above the acid dew point of the sample. Flue gas diffuses through a large filter at the end of the probe which acts as a sample chamber. A convection loop contains the zirconium oxide oxygen cell. Due to the natural convection generated by the temperature difference between the cell location (695°C) and the return leg (approximately 215°C), a portion of the filter contents is drawn into the convection loop, past the combustibles detector and oxygen cell then back to the filter. The controlled conditions of the convection loop are ideally suited to the catalytic combustibles detector which benefits from a constant temperature and constant flow environment.

### CONVECTION PRINCIPLE

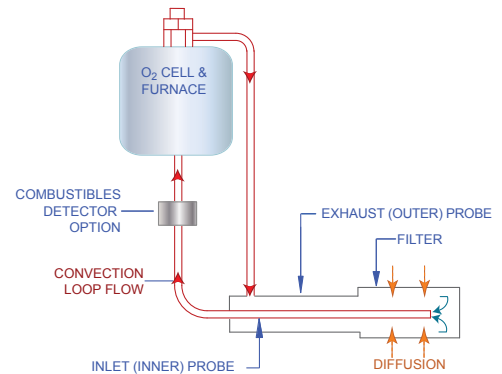

### HP SERIES SENSOR DETAILS

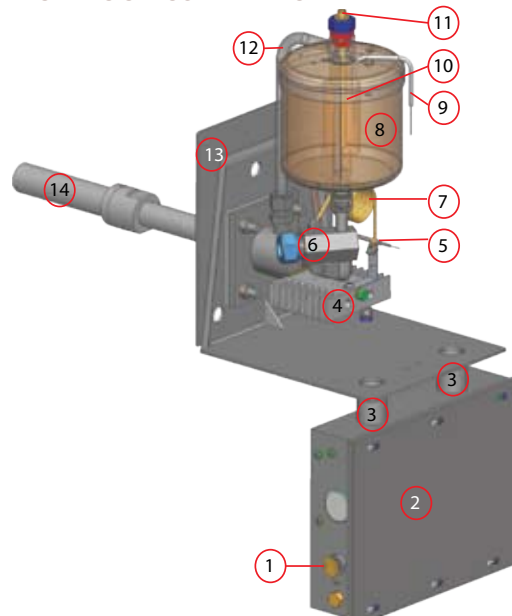

- 1 PLUG-IN CONNECTOR (IQ ONLY)
- 2 TERMINAL BOX
- 3 INTERNAL WIRE CONDUITS
- 4 HEATER BLOCK ASSEMBLY
- 5 BOX TEMPERATURE SENSOR
- 6 COMBUSTIBLES DETECTOR (OPTION)
- 7 CALIBRATION GAS LINE
- 8 FURNACE (CELL HEATER)
- 9 THERMOCOUPLE
- 10 CELL HOUSING
- 11 OXYGEN CELL (ZIRCONIA)
- 12 CONVECTION LOOP RETURN
- 13 MOUNTING BACKPLATE
- 14 PROBE

# WDG-INSITU

## FLUE GAS OXYGEN ANALYZER

The WDG-Insitu is a direct insertion-type oxygen probe where the zirconium oxide cell is directly in the stream of the products of combustion. The patented WDG-Insitu is designed for applications where the flue gas temperature does not exceed 1250°F (677°C) and where combustibles measurements are not required. The outer probe material is highly resistant to corrosion. For hazardous area locations, explosion-proof and purged versions are available. For high particulate applications, a filter can easily be added.



WDG-Insitu

### SIMPLIFIED CONSTRUCTION FOR EASY SERVICE

With the unique design of the WDG-Insitu oxygen probe, field replacement of all components is easily performed. While the outer protection tube remains in the process, the inner probe, housing the oxygen cell and heater/thermocouple assembly, can be removed easily. With no need to return the probe to the factory, extensive down time and expensive repairs on your oxygen insitu probe are avoided.

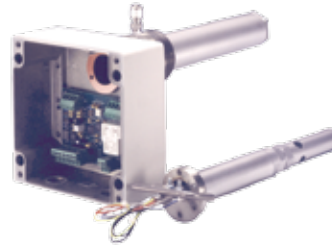

Open WDG-Insitu with Inner Probe Removed

For more detailed information, ask for bulletin —

- P-300 (WDG-Insitu)
- P-490 (WDG Insitu/IQ)

### INSITU SENSOR DETAILS

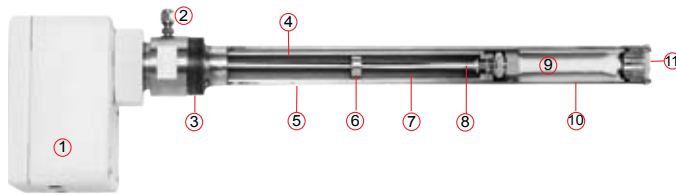

- 1 NEMA 4X JUNCTION BOX
- 2 1/4" COMPRESSION CONNECTION FOR CALIBRATION GAS
- 3 2" NPT (M) CONNECTION FOR FLANGE ADAPTION
- 4 INNER TUBE STRUCTURE
- 5 OUTER PROTECTION TUBE (NO NEED TO REMOVE ONCE INSTALLED)
- 6 SUPPORT SPIDERS
- 7 ZIRCONIUM OXIDE CELL LEAD(S)
- 8 ZIRCONIUM OXIDE CELL HEATER/THERMOCOUPLE
- 9 ZIRCONIUM OXIDE CELL WITH INSULATION SLEEVE
- 10 CERAMIC SHEATH
- 11 PROTECTIVE SCREEN

## WDG 210/INSITU

This rugged and reliable flue gas analyzer for net oxygen is ideal as a cost-effective solution for oxygen monitoring when minimum features are required. The 210 Control Unit features menu-driven software and includes field-configurable alarms and current output and system diagnostics.

### APPLICATIONS

- Package boiler manufacturers
- Combustion control systems
- Gas, oil, or coal-fired boilers
- NOx reduction system
- Shipboard boilers

For more detailed information, ask for bulletin —

- P-440 (WDG 210/INSITU)



Series 210 Control Unit and WDG 210/Insitu

## CEM/O<sub>2</sub>, CEM O<sub>2</sub>/IQ, AND RM CEM/O<sub>2</sub> IQ

### EXTRACTIVE FLUE GAS OXYGEN ANALYZER

For applications where a sample is taken to a remote analyzer location, the cost-effective CEM/O<sub>2</sub> analyzer family provides advanced systems features that integrate into your overall emissions monitoring system. The analyzer complies with 40 CFR Part 60 and Part 75 Federal EPA performance specification requirements along with regional requirements for oxygen monitors.

The CEM/O<sub>2</sub> analyzer is available as an IQ version or with a separate Series 2000 Control Unit.

The RM CEM O<sub>2</sub>/IQ integrates sensor and controller in a single 19" rack mount package.

Custom designs, packaging, labeling, and software can be provided, as well as OEM stocking and delivery agreements.



CEM O<sub>2</sub>/IQ  
with Handheld IQ Link

#### APPLICATIONS

- CEM applications
- Emissions and compliance
- Extractive sampling systems
- Instrumentation panels



RM CEM O<sub>2</sub>/IQ

## CEM/HUMOX

### MEASUREMENT OF MOISTURE IN FLUE GAS

The CEM/Humox system consists of two CEM/O<sub>2</sub> sensors (one dry and the other wet) and a special version of the Series 2000 Control Unit. It calculates the moisture in flue gas from the separate wet and dry oxygen sensor inputs. The system is designed to measure net oxygen and moisture content in flue gas and process applications. The O<sub>2</sub> and moisture data is used to correct emissions, assure product quality, or minimize stack corrosion. The analyzer indicates moisture, oxygen-wet and oxygen-dry concentrations in percent by volume.



CEM/Humox System

.....  
For more detailed information, ask for bulletin –

- P-400 (CEM/O<sub>2</sub>)
- P-500 (CEM O<sub>2</sub>/IQ)
- P-460 (CEM/Humox) or
- P-640 (RM CEM/O<sub>2</sub> IQ)

### EXTRACTIVE ANALYZERS

Extractive analyzers are located remotely from the sample point. The sample can be delivered to the analyzer through a heated sample line (hot, wet) or cooled to remove the moisture (dry). With zirconium oxide either method can be used. Most of the sample passes straight through the analyzer. A portion flows into the convection loop and is measured by the oxygen cell.

#### CEM/O<sub>2</sub> SENSOR DETAILS

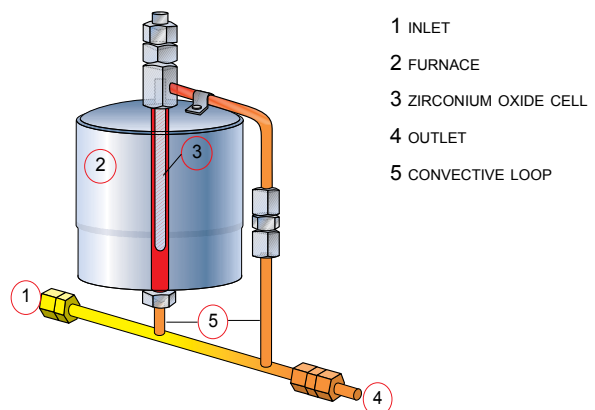

## EXCESS FUEL OPTION

### MONITOR EXCESS FUEL ATMOSPHERES

With the Excess Fuel option, you can monitor processes containing fuel-rich atmospheres such as bright annealing or decarburizing applications, or for the fume stage of an incinerator.

The excess fuel software enables fuel-rich atmospheres to be measured. It displays and provides alarms and analog outputs for the following:

- Excess fuel
- Combustibles
- Oxides-to-fuels ratio
- Fuels-to-oxides ratio

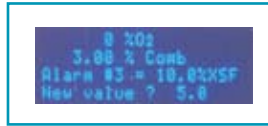
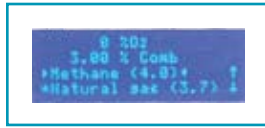

#### FEATURES

- User-selectable inputs include defining the hydrogen-to-carbon ratio (H/C) of the fuel or selecting from a menu of common fuels.
- Alarms can be set for high or low readings.
- Analog output and display scalable to cover combined excess oxygen to excess fuel/combustibles ranges.
- Two-point calibration in excess fuel range.

#### APPLICATIONS

- Annealing
- Decarburizing
- Furnace atmospheres
- Heat treating
- Incinerators
- Water-to-hydrogen ratio

#### THEORY OF OPERATION

*In the absence of molecular oxygen, the zirconium oxide cell responds to minute amounts of oxygen produced by the dissociation of water or carbon dioxide at the high cell operating temperature. This dissociation is inhibited by the presence of combustibles in the sample gas. As the combustibles concentration increases, the oxygen concentration decreases, and the output signal from the cell becomes greater. This means that the cell keeps responding when there is no net oxygen in the flue gas. In fact, it becomes a sensor of net combustibles.*

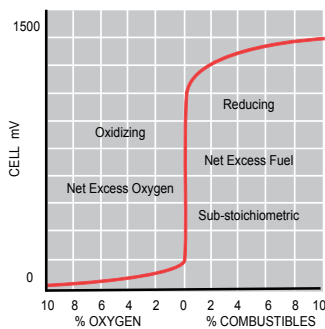

Zirconia cell output for Excess Oxygen and Excess Fuel

## AUTOMATIC CALIBRATION OPTION

### SIMPLIFIES CALIBRATION OF ANALYZER

The Remote Calibration Unit and the Calibration Module allow automatic calibration of your analyzer.

With calibration gases permanently connected to the Remote Calibration Unit, you can program the Series 2000 or IQ-based analyzers to activate a calibration cycle at a timed interval. A calibration can also be performed remotely on demand by contact closure or via the RS-485 communications port. In addition, you can calibrate locally by manually pressing keys on the Series 2000 or IQ Link.

Similarly, a verification can be performed in which the calibration gas values are recorded but no changes are made to the calibration settings in the analyzer.

Automatic calibration capabilities can be easily added to an analyzer at a later date by simply plugging a Calibration Module into the Series 2000 or IQ analyzer and installing a Remote Calibration Unit near the sensor.

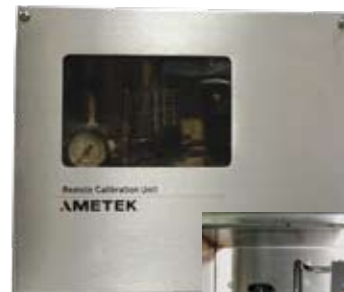

Remote Calibration Unit

# HAZARDOUS AREA CLASSIFICATION OPTIONS

## ATEX II 3 G (ZONE 2) MODELS

### SERIES 2000 BASED

WDG-IV Oxygen  
 WDG-IVC Oxygen & Combustibles  
 WDG-IVCM Oxygen, Combustibles & Methane  
 WDG-IV UOP/RP  
 WDG-HPII Oxygen  
 WDG-HPIIC Oxygen & Combustibles

### SMART SENSOR VERSIONS

WDG IV/IQ Oxygen  
 WDG IVC/IQ Oxygen & Combustibles  
 WDG IVM/IQ Oxygen & Methane  
 WDG IVCM/IQ Oxygen, Combustibles & Methane  
 WDG HPII/IQ Oxygen  
 WDG HPIIC/IQ Oxygen & Combustibles

### TYPE APPROVAL (LCIE 05 ATEX 6140 X and LCIE 05 ATEX 6140 X / 01)

Series 2000 Control Unit	⊕ II 3 G EEx nA IIC T3	-10°C ≤ Ta ≤ 50°C
WDG...	⊕ II 3 G EEx nZ IIC T3	-20°C ≤ Ta ≤ 60°C

- .....  
 For more detailed information, ask for bulletin —
- P-700 (WDG-IV Series)
  - P-710 (WDG-HPII Series)
  - P-720 (WDG-IV UOP/RP)



## ATEX II 2 G (ZONE 1) MODELS

The CENELEC WDG-Insitu is certified to ⊕ II 2 G, EEx d IIC T3 when used with a Series 2000 Control Unit, or to EEx d IIB T2 if used with a non-Thermox control unit.

- The Series 2000 is certified to ⊕ II 2 G, EEx d IIC T6.
- The optional Remote Calibration Unit (RCU) is certified to ⊕ II 2 G, EEx d IIC T5, and can be used with the CENELEC Insitu or CENELEC WDG-IV/IVC analyzers.

- .....  
 For more detailed information, ask for bulletin —
- P-250 (WDG-IV/IVC CENELEC)
  - P-30C (WDG-Insitu CENELEC)



# HAZARDOUS AREA CLASSIFICATION OPTIONS



WDG-IV/IVC  
Explosion Proof  
NEC Class I, Division 1

**NEC CLASS I, DIVISION 1**  
Explosion-proof versions of the WDG sensor and Series 2000 Control Unit are designed to meet NEC Class I, Division 1 requirements.



WDG-INSITU  
NEC Class I, Division 2



WDG-IV/IVC Z-Purged  
NEC Class I, Division 2

- NEC CLASS I, DIVISION 2**
- The Series 2000 Control Unit and IQ Link are UL-approved for NEC Class I, Division 2, Groups A, B, C, and D classifications without the need for a Z-purge apparatus.
  - The WDG-IV, WDG-IVC, WDG-IVM, WDG-HPII, WDG-HPIIC, and WDG-HPIIM analyzers with the Division 2 option are UL-approved for NEC Class I, Division 2, Groups A, B, C, and D classifications.
  - Optional pressure switch is available if the site does not have an alarm on the protective gas supply.



WDG-IV/IVC  
Z-Purged with Pressure Switch  
NEC Class I, Division 2

## HAZARDOUS LOCATION - IQ LINKS

Both the handheld and wall mount terminals are approved for NEC Class I, Division 2, Groups A, B, C and D, and ATEX II 3 G hazardous areas.

Handheld IQ Link	⊕ II 3 G EEx nL IIC T4	-20°C ≤ Ta ≤ 70°C
Wall Mount IQ Link	⊕ II 3 G EEx nA IIC T4	-20°C ≤ Ta ≤ 70°C



Handheld and Wall  
Mount IQ Links

## OTHER THERMOX GAS ANALYZERS

All Thermox analyzers use the Series 2000 or IQ microprocessor-based control electronics. They are designed with an emphasis on reliability, serviceability, ease-of-use, and digital communications.

In addition to our flue gas analyzers, Thermox offers analyzers for industrial gas and pre-mix gas applications. These analyzers use the Series 2000 Control Unit.

### TRACE OXYGEN ANALYZERS

For nitrogen purity and other industrial applications, Thermox TM2000 and CG1000 industrial gas oxygen analyzers provide a quick response time to process changes, and operate from 100% to 0.1 ppm O<sub>2</sub>.

.....  
For more detailed information, ask for bulletin —

- P-410 (TM2000) or
- P-420 (CG1000)



CG1000 Analyzer



TM2000 Analyzer

13

For applications which may have particulate or other components, the CEM O<sub>2</sub>/TM provides fast, reliable performance.

.....  
For more detailed information, ask for bulletin P-660.



CEM O<sub>2</sub>/TM Analyzer

### PRE-MIX GAS ANALYZERS

The Thermox PreMix 2000 and CMFA-P 2000 (portable) analyzers accurately and continuously measure the proportions of oxygen and fuel in pre-mix gases. They are used wherever efficient control is required for an open flame combustion process such as in glass and fiber glass manufacturing or in flame treating applications.

.....  
For more detailed information, ask for bulletin —

- P-430 (PreMix) or
- P-580 (CMFA-P 2000)



PreMix 2000 Analyzer



CMFA-P 2000 Analyzer

# FLUE GAS ANALYZER GUIDE

ANALYZER TYPE	WDG-IV	WDG-IVC	WDG-IVCM	WDG-HPII	WDG-HPIIC	WDG-INSITU	CEM/O <sub>2</sub>
(NOTE 1)	CCX	CCX	CCX	CONV	CONV	INS	EXT
<b>GAS MEASURED</b>							
OXYGEN	YES	YES	YES	YES	YES	YES	YES
COMBUSTIBLES	NO	YES	YES	NO	YES	NO	NO
METHANE	NO	NO	YES	NO	NO	NO	NO
EXCESS FUEL (OPTION)	YES	NO	NO	YES	NO	NO	YES
<b>DISPLAY RANGE</b>							
OXYGEN	0.1-100%	0.1-100%	0.1-100%	0.1-100%	0.1-100%	0.1-100%	0.1-100%
COMBUSTIBLES	—	0-10,000PPM OR 0-5%	0-10,000PPM OR 0-5%	—	0-10,000PPM OR 0-5%	—	—
METHANE	—	—	0-5%	—	—	—	—
<b>OUTPUT RANGE</b>							
OXYGEN	0-1% TO 0-100%	0-1% TO 0-100%	0-1% TO 0-100%	0-1% TO 0-100%	0-1% TO 0-100%	0-1% TO 0-100%	0-1% TO 0-100%
COMBUSTIBLES	—	0-2,000PPM TO 0-10,000PPM OR 0-1% TO 0-5%	0-2,000PPM TO 0-10,000PPM	—	0-2,000PPM TO 0-10,000PPM OR 0-1% TO 0-5%	—	—
METHANE	—	—	0-5%	—	—	—	—
<b>ACCURACY (NOTE 2)</b>							
OXYGEN	±0.75% M.V. OR ± 0.05% O <sub>2</sub>	±0.75% M.V. OR ± 0.05% O <sub>2</sub>	±0.75% M.V. OR ± 0.05% O <sub>2</sub>	±0.75% M.V. OR ± 0.05% O <sub>2</sub>	±0.75% M.V. OR ± 0.05% O <sub>2</sub>	±1% M.V. OR ± 0.05% O <sub>2</sub>	±0.75% M.V. OR ± 0.05% O <sub>2</sub>
COMBUSTIBLES	—	±2% F.S.	±2% F.S.	—	±2% F.S.	—	—
METHANE	—	—	±5% F.S.	—	—	—	—
<b>RESPONSE TIME (NOTE 3)</b>							
INITIAL	<2 SEC	<2 SEC	<3 SEC	<5 SEC	<5 SEC	<5 SEC	<2 SEC
TO 63% OF FINAL VALUE	<3 SEC	<5 SEC	<10 SEC	<16 SEC	< 20 SEC	<25 SEC	<4 SEC
<b>MAX FLUE GAS TEMPERATURE</b>	3000°F (1648°C)	3000°F (1648°C)	3000°F (1648°C)	2800°F (1537°C)	2800°F (1537°C)	1250°F (677°C)	400°F (204°C)
<b>INSTRUMENT AIR SUPPLY</b>	10-20 CFH @15-100 PSI	10-20 CFH @15-100 PSI	10-20 CFH @15-100 PSI	NOT REQUIRED	NOT REQUIRED	CENELEC + DIV 2 ONLY	NOT REQUIRED

APPLICATIONS (NOTE 4)	WDG-IV	WDG-IVC	WDG-IVCM	WDG-HPII	WDG-HPIIC	WDG-INSITU	CEM/O <sub>2</sub>
GAS & LIGHT OIL-FIRED BOILERS	A	A	A	A	A	A	D
HEAVY OIL, WOOD & COAL-FIRED BOILERS	E	E	E	A	A	A	D
FIRED HEATERS	A	A	A	B	B	A	D
ROTARY KILNS	F	F	F	A	A	A	D
RECOVERY BOILERS	C	C	C	A	A	A	D
INCINERATORS	B	B	B	A	A	B	D
PACKAGE BOILERS	B	B	B	A	A	A	D
FURNACE ATMOSPHERES	A	C	C	A	C	—	D
COMBUSTION CONTROL SYSTEMS	A	A	A	A	A	A	D
ENVIRONMENTAL COMPLIANCE	B	G	G	B	G	B	D

2007.1

**NOTES:**

- ANALYZER TYPE: CCX - CLOSE-COUPLED EXTRACTIVE, INS = INSITU, CONV = CONVECTIVE, EXT = EXTRACTIVE
- EXPRESSED AS ± PERCENT OF EITHER MEASURED VALUE (M.V.) OR FULL SCALE (F.S.) OUTPUT RANGE, OR PERCENT OXYGEN, WHICHEVER IS GREATER. ALL STATIC PERFORMANCE CHARACTERISTICS ARE WITH OPERATING VARIABLES CONSTANT. SYSTEM ACCURACY REFERENCED TO 0.1 TO 10% CALIBRATED RANGE.
- RESPONSE TO CAL GAS WITHOUT FLAME ARRESTERS.
- RATING SYSTEM: A = EXCELLENT  
B = GOOD  
C = NOT RECOMMENDED  
D = USED WITH SAMPLE CONDITIONING SYSTEM OR HEATED SAMPLE LINE.  
E = SUITABLE WITH FILTER AND OPERATIONAL PRECAUTIONS.  
F = NORMALLY INSTALLED ON THE END OF CUSTOMER'S SAMPLE CONDITIONING SYSTEM.  
G = COMBUSTIBLES AND METHANE NOT USED FOR EMISSION/COMPLIANCE APPLICATIONS.

**OTHER PRODUCTS FROM  
AMETEK PROCESS INSTRUMENTS**

CEM SYSTEMS  
TUNABLE DIODE LASER ANALYZERS  
HYDROCARBON AND WATER DEWPOINT ANALYZERS  
PHOTOMETRIC ANALYZER SYSTEMS  
PROCESS MASS SPECTROMETERS  
RESIDUAL GAS ANALYZERS  
TRACE IMPURITIES (H<sub>2</sub>, CO, CO<sub>2</sub>, CH<sub>4</sub> AND NMHC)  
TRACE OXYGEN ANALYZERS  
TRACE MOISTURE ANALYZERS



**PROCESS INSTRUMENTS**

150 FREEPORT ROAD • PITTSBURGH, PA 15238 USA  
PHONE 412.828.9040 • FAX 412.826.0399  
WWW.THERMOX.COM  
WWW.AMETEKPI.COM

**PROCESS INSTRUMENTS LOCATIONS**

- USA 150 FREEPORT ROAD • PITTSBURGH, PA 15238 • PHONE: 412-828-9040 • FAX: 412-826-0399  
455 CORPORATE BLVD. • NEWARK, DE 19702 • PHONE: 302-456-4400 • FAX: 302-456-4444  
2001 NORTH INDIANWOOD AVENUE • TULSA, OK 74012-1163 • PHONE: 918-250-7200 • FAX: 918-459-0165  
9750 WHITHORN DRIVE • HOUSTON, TX 77095 • PHONE: 281-463-2820 • FAX: 281-463-2701
- CANADA 2876 SUNRIDGE WAY N.E. • CALGARY, AB T1Y 7H9, CANADA • PHONE: 403-235-8400 • FAX: 403-248-3550
- CHINA AMETEK BEIJING • CITIC BUILDING, ROOM 2305 • 19, JIANGUOMENWAI DAJIE • BEIJING 100004, P.R. CHINA • PHONE: 86-10-8526-2111 • FAX: 86-10-8526-2141  
AMETEK CHENGDU REP OFFICE • RM 2408 ZONGFU BUILDING • NO 35 ZONGFU ROAD • CHENGDU 610016, SICHUAN PR CHINA • PHONE: 86-28-86758111 • FAX: 86-28-86758141  
AMETEK SHANGHAI (SPL) • ROOM 912, METRO TOWER • NO. 30 TIAN YAO QIAO ROAD • SHANGHAI 200030 P.R. CHINA • PHONE: 86-21-6426-8111 • FAX: 86-21-6426-7818
- FRANCE AMETEK PRECISION INSTRUMENTS • ROND POINT DE L'EPINE DES CHAMPS • BUROPLUS BAT D • 78990 ELANCOURT FRANCE • PHONE: 33-1-30-68-89-20 • FAX: 33-1-30-68-89-29
- GERMANY AMETEK GMBH • RUDOLF-DIESEL-STRASSE 16 • D-40670 MEERBUSCH GERMANY • PHONE: 49-2159-9136-0 • FAX: 49-2159-9136-39
- MIDDLE EAST AMETEK DUBAI • PO BOX 17067 • JEBEL ALI FREE ZONE • DUBAI, UAE • PHONE: 971-4-881-2052 • FAX: 971-4-881-2053
- SINGAPORE AMETEK SINGAPORE PTE. LTD. • 10 ANG MO KIO STREET 65 • #05-12 TECHPOINT • 569059 SINGAPORE • PHONE: 65-6484-2388 • FAX: 65-6481-6588

