

Mobile Calibration System with Battery Buffer



MK5-BNT as Permeation System

The mobile calibration system MK5-BNT is available in two designs. Once as a permeation system to produce span gases according to the permeation method or with an ozon generator to produce ozon span gases - optionally with the added possibility for gas phase titration. Both designs possess an internal zero gas supply for the calibration process, and a battery pack supply for the permeation oven, which allows the system about 8 hours of standby operability without being connected to a power outlet.

The system is suitable for full dynamically multi point calibrations with mobile measuring readings or as a transfer standard for the alignment of analyzers at different locations.

Mobile Calibration System MK5-BNT

- **Mobile transfer standard for span gases**
- **Span gas production according to the permeation method or ozonizer and gas phase titration**
- **Quickly operational through standby mode**
- **Standby operation via internal battery pack or 12V automobile power supply for the permeation oven**
- **Measurement results from various measuring stations can be compared using a transfer standard**

The advantages of a battery buffered calibration system compared to a standard device consist mainly in the fast availability of the span gases after a location change and in the high level of reproducibility of the span gas concentration. This is achieved by maintaining the stability determining basic functions such as the temperature of the permeation furnace, or a flushing of the analytical assembly groups, etc. through the power supplied by the battery pack (standby operation). In contrast to the use of bottled span gas as the transfer standard, a permeation system is significantly easier to handle and makes the transport of heavy and unwieldy span gas bottles

Umwelttechnik MCZ GmbH
Dieselstraße 20a
61239 Ober-Mörlen
Tel: 0 60 02 / 1711
Fax: 0 60 02 / 17 13

Distributor:

Mobile Calibration System MK5-BNT

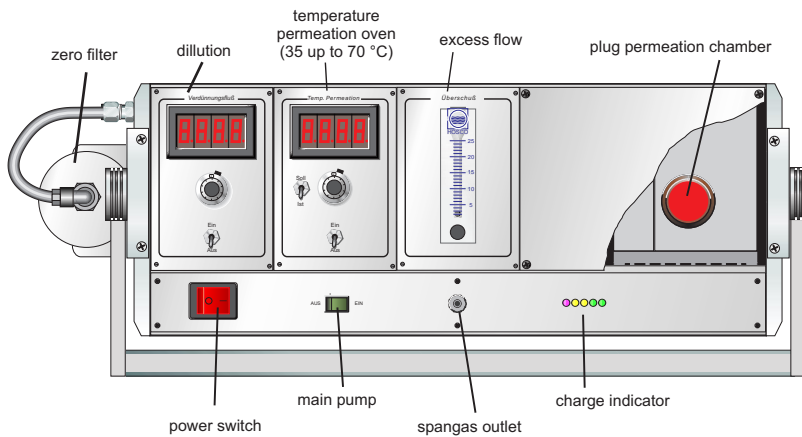

MK5-BNT as Permeation System

All assembly groups, including the zero gas supply and the battery, are contained within a 19" / 4 HE cabinet. The systems for the generation of ozone laden span gases feature an ozonizer instead of a permeation furnace. If in special circumstances the internal preparation of the zero gas might not suffice, it is possible to connect a source with externally prepared zero gas to the calibration system.

The permeation system of the MK5-BNT is equipped with its own pump to ensure a low energy consumption during the standby operation mode of the system. This increases the buffer time to more than 8 hours, without having to forego a purge gas flow. The temperature of the permeation furnace and the operation of the UV lamp of the ozon generator, respectively, are also sustained via the battery pack.

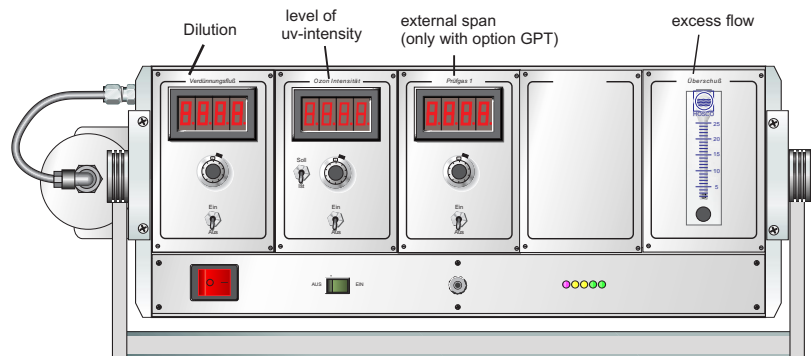

MK5-BNT as Ozon Generator and with Gas Phase Titration

Option internal zero gas supply

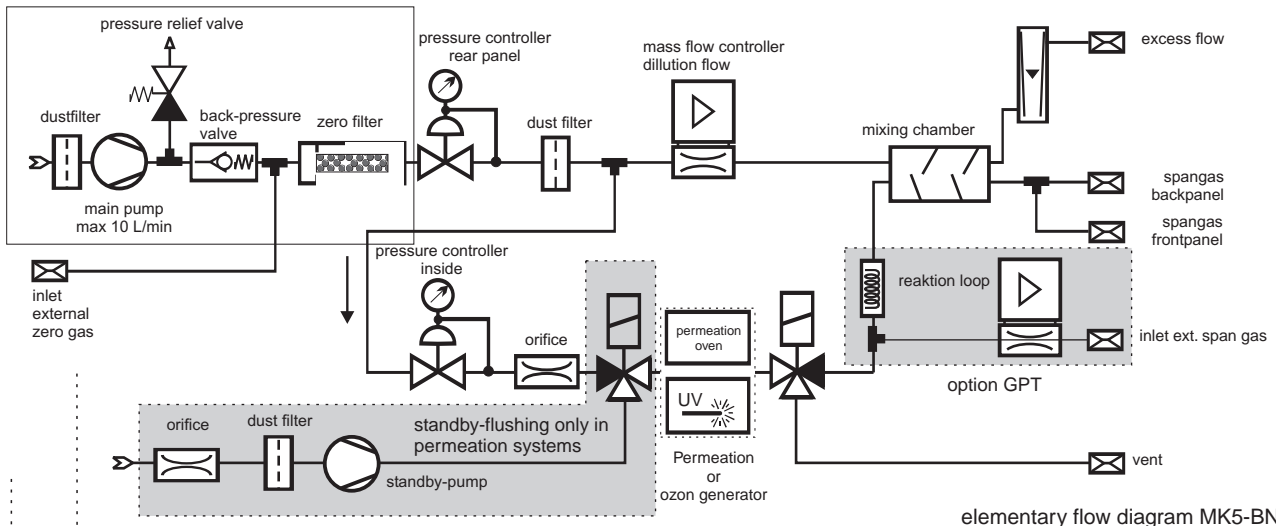

elementary flow diagram MK5-BNT

specifications MK5-BNT

permeation oven:	
range	35 up to 70 °C
temperature accuracy	± 0.05°C
ozon generator:	
range	5 up to 600 ppb at 2.5 L/min
repeatability	better +/-1,5ppb Optical feedback

general specifications:	
flow control	dilution with mass flow controller permeation / O ₃ with orifice selectable by customer
max. span gas flow	min. 1:5, max. 1:2000
Dilution ratio	typ. <+/-0,6% FS, max. < +/-1%FS
accuracy MFC	< +/- 0,25%
Repeatability	>= 8 h with internal battery
standby mode	
dimension	19", 4 HE