



## Gas cooler series EGK 1SD

In the chemical industry, petrochemistry or biochemistry, reliable process control relies on prompt and exact determination of the operating parameters.

Here, gas analysis is the key for safe and efficient control of process flows, environmental protection and quality assurance. This benefits controlling flue gas emission in power stations or exhaust gas analysis in automotive engineering, as well as the efficient control of air separators or sterile production and packaging in the food industry.

Many of the analysis processes used in these fields require extracting the sample gas. This inevitably also extracts process-related contamination such as particles or moisture. These in turn can impact the measurement results or damage the measuring cells. The sample gas must therefore be conditioned before entering the analyser.

The EGK 1SD is a medium duty compressor sample gas cooler. It can be wall-mounted or used as a table-top cooler with up to two gas paths.

Compact installation

One or two gas paths

Heat exchanger made from stainless steel, Duran glass or PVDF

Bühler constant control system

Self-monitoring

Cooling block temperature display

Status alarm

Rated cooling power 320 kJ/h

Dew point stability  $\pm 0.1^\circ\text{C}$

CFC-free

FM approved



Performance data

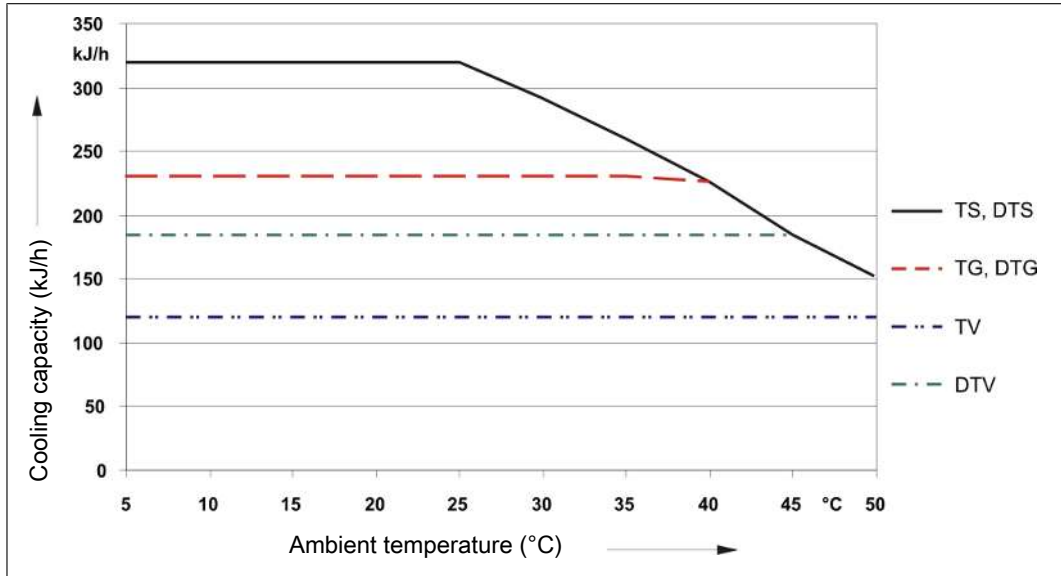

Remark: The limit curves for the heat exchangers exchanger apply to a dew point of 65 °C.

Technical Data

Gas Cooler Technical Data

Ready for operation:	after max. 15 minutes	
Rated cooling capacity (at 25 °C):	320 kJ/h	
Ambient temperature:	5 °C to 50 °C	
Gas output dew temperature, preset:	5 °C	
Dew point fluctuations		
static:	± 0.1 K	
in the entire specification range:	± 1.5 K	
IP rating:	IP 20	
Housing:	Stainless steel	
Weight incl. heat exchanger:	approx. 15 kg	
Electric supply:	115 V, 60 Hz or 230 V, 50 Hz Plug per EN 175301-803	
Electrical data:	230 V	115 V
	Typical power input:	140 VA
	max. operating current:	1.6 A
		155 VA
		3.2 A
Alarm output switching connection:	250 V, 2 A, 50 VA Plug per EN 175301-803	
Packaging dimensions:	approx. 420 mm x 440 mm x 350 mm	
FM approval no.:	3040918	

Diagram typical installation

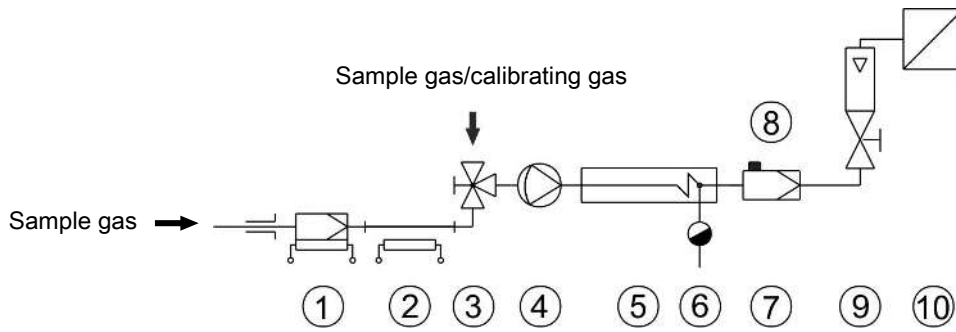

1 Sample gas probe	2 Sample gas line
3 Reversing tap	4 Sample gas pump
5 Sample gas cooler	6 Automatic condensate drain or peristaltic pump
7 Fine mesh filter	8 Moisture detector
9 Flow meter	10 Analyser

See data sheets for individual component models and data.

Heat exchanger description

The energy content of the sample gas and the required cooling capacity of the gas cooler is determined by three parameters: gas temperature  $\vartheta_G$ , (inlet) dew point  $\tau_e$  (moisture content) and volume flow  $v$ . The outlet dew point rises with increasing energy content of the gas. The approved energy load from the gas is therefore determined by the tolerated rise in the dew point.

The following limits are specified for a normal standard operating point of  $\tau_e = 65^\circ\text{C}$  and  $\vartheta_G = 90^\circ\text{C}$ . The maximum volume flow  $v_{\text{max}}$  in NI/h of cooled air is indicated, so after moisture has condensed.

If the values fall below  $\tau_e$  and  $\vartheta_G$ , the flow  $v_{\text{max}}$  may be increased. For example, on the TG heat exchanger the parameter triple  $\tau_e = 65^\circ\text{C}$ ,  $\vartheta_G = 90^\circ\text{C}$  and  $v = 280$  NI/h may also be used in place of  $\tau_e = 50^\circ\text{C}$ ,  $\vartheta_G = 80^\circ\text{C}$  and  $v = 380$  NI/h

Please contact our experts for clarification or refer to our design program.

Heat exchanger overview

Heat exchanger	TS TS-I <sup>2)</sup>	TG TG	TV-SS TV-SS-I <sup>2)</sup>	DTS (DTS-6 <sup>3)</sup> ) DTS-I (DTS-6-I <sup>3)</sup> ) <sup>2)</sup>	DTG DTG	DTV <sup>3)</sup> DTV-I <sup>2)3)</sup>
Version / Material	Stainless steel	Glass	PVDF	Stainless steel	Glass	PVDF
Flow rate $v_{\text{max}}$ <sup>1)</sup>	530 L/h	280 L/h	155 L/h	2 x 250 L/h	2 x 140 L/h	2 x 115 L/h
Inlet dew point $\tau_{e,\text{max}}$ <sup>1)</sup>	80 °C	80 °C	65 °C	80 °C	65 °C	65 °C
Gas inlet temperature $\vartheta_{G,\text{max}}$ <sup>1)</sup>	180 °C	140 °C	140 °C	180 °C	140 °C	140 °C
Max. Cooling capacity $Q_{\text{max}}$	450 kJ/h	230 kJ/h	120 kJ/h	450 kJ/h	230 kJ/h	185 kJ/h
Gas pressure $p_{\text{max}}$	160 bar	3 bar	3 bar	25 bar	3 bar	2 bar
Pressure drop $\Delta p$ ( $v=150$ L/h)	8 mbar	8 mbar	8 mbar	5 mbar each	5 mbar each	15 mbar each
Dead volume $V_{\text{tot}}$	69 ml	48 ml	129 ml	28 / 25 ml	28 / 25 ml	21 / 21 ml
Gas connections (metric)	G1/4	GL 14 (6 mm) <sup>4)</sup>	DN 4/6	6 mm tube	GL14 (6 mm) <sup>4)</sup>	DN 4/6
Gas connections (US)	NPT 1/4"	GL 14 (1/4") <sup>4)</sup>	1/4"-1/6"	1/4" tube	GL14 (1/4") <sup>4)</sup>	1/4"-1/6"
Condensate out connections (metric)	G3/8	GL 25 (12 mm) <sup>4)</sup>	G3/8	Tube 10 mm (6 mm)	GL18 (10 mm) <sup>4)</sup>	DN 5/8
Condensate out connections (US)	NPT 3/8"	GL 25 (1/2") <sup>4)</sup>	NPT 3/8"	Tube 3/8" (1/4")	GL18 (3/8") <sup>4)</sup>	3/16"-5/16"

<sup>1)</sup> Max. cooling capacity of the cooler must be considered

<sup>2)</sup> Models marked I have NPT threads or US tubes, respectively.

<sup>3)</sup> Condensate drain only possible with condensate pump

<sup>4)</sup> Gasket inside diameter

Dimensions

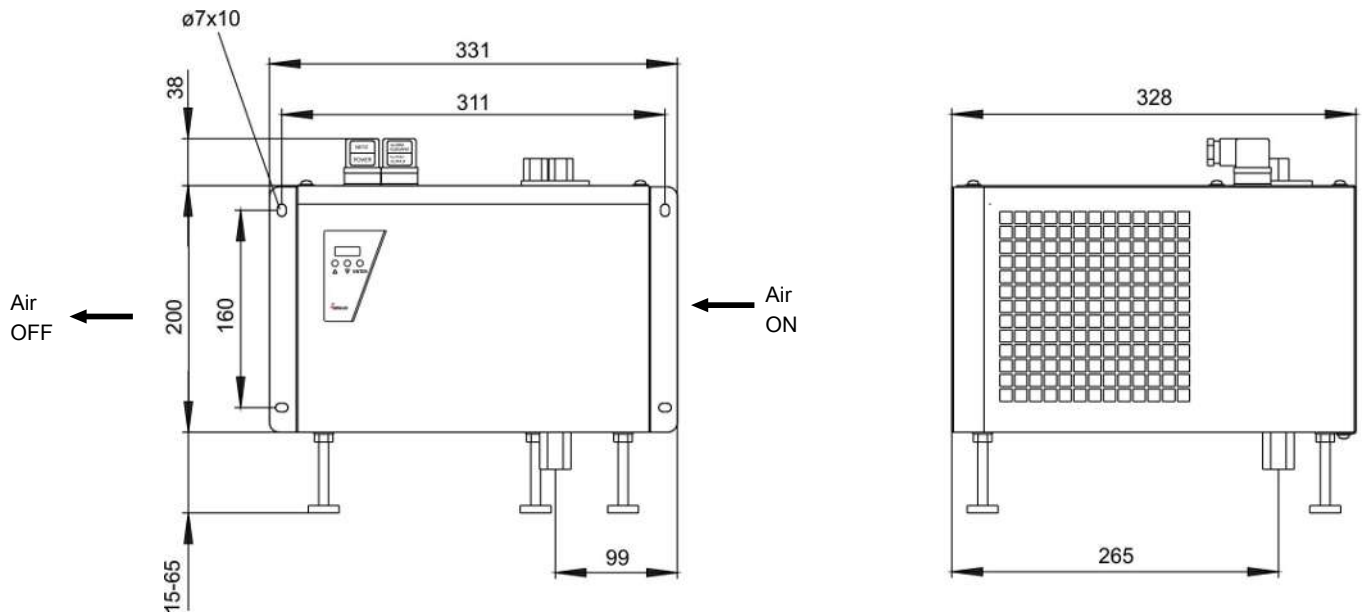

Ordering instructions

The item number is a code for the configuration of your unit. Please use the following model key:

**Please note:** Every individual gas path must be equipped with peristaltic pump or condensate drain.

4561	X	X	X	X	0	0	0	0	Product Characteristics
<b>Voltage</b>									
1									115 V metric screw connections
2									230 V metric screw connections
3									115 V US screw connections
4									230 V US screw connections
<b>Gas path / Material / Version</b>									
0	0	0							without heat exchanger
1	1	0							1 gas path / single stainless steel heat exchanger / (TS or TS-I)
1	2	0							1 gas path / single glass heat exchanger / (TG)
1	3	0							1 gas path / single PVDF heat exchanger / (TV-SS or TV-I)
2	6	0							2 gas paths / dual stainless steel heat exchanger / (DTS or DTS-I)
2	6	1							2 gas paths / dual stainless steel heat exchanger / (DTS-6 or DTS-6-I) <sup>1)</sup>
2	7	0							2 gas paths / dual glass heat exchanger / (DTG)
2	8	0							2 gas paths / dual PVDF heat exchanger / (DTV or DTV-I) <sup>1)</sup>
<b>Condensate drain<sup>2)</sup></b>									
			0	0	0	0			

<sup>1)</sup> Condensate outlets only suitable for connecting peristaltic pumps.

<sup>2)</sup> Peristaltic pumps available for separate installation.

Spare parts and accessories

Item no.	Description
44 10 00 1	Automatic condensate drain 11 LD V 38
44 10 00 4	Automatic condensate drain AK 20, PVDF
44 10 00 5	Condensate trap GL 1; glass, 0.4 L
44 10 01 9	Condensate trap GL 2; glass, 1 L
see data sheet 450020	Peristaltic Pump CPsingle, CPdouble