



Gas cooler series EGK 2A Ex

In the chemical industry, petrochemistry or biochemistry, reliable process control relies on prompt and exact determination of the operating parameters.

Here, gas analysis is the key for safe and efficient control of process flows, environmental protection and quality assurance. This benefits controlling flue gas emission in power stations or exhaust gas analysis in automotive engineering, as well as the efficient control of air separators or sterile production and packaging in the food industry.

Many of the analysis processes used in these fields require extracting the sample gas. This inevitably also extracts process-related contamination such as particles or moisture. These in turn can impact the measurement results or damage the measuring cells. The sample gas must therefore be conditioned before entering the analyser.

The EGK 2A Ex is ATEX and IECEx approved and equipped with up to four separate gas paths, making it suitable for operation in explosive zones. It has a digital temperature display and alarm outputs.

ATEX and IECEx approval for Zone 1

CFC-free

Rated cooling power 583 Btu/h

1 or 2 heat exchangers plug-in: up to 4 gas paths

Self-monitoring with temperature alarm output

Status display and output

Easy to use and inspect

Easy to install construction

Condensate drain inside device available

Auto-start if refrigerant circuit intact



Technical Data

Gas Cooler Technical Data

ATEX approval	Ex II 2 G Ex pxb eb mb q [ia] IIC T4 Gb
IECEx approval	Ex pxb eb mb q [ia] IIC T4 Gb
Ready for operation	after max. 20 minutes
Rated cooling capacity (at 77 °F)	> 583 Btu/h (170 W)
Ambient temperature	-4 °F to 113 °F
Gas output dew temperature preset:	41 °F
adjustable:	36 °F to 68 °F
Alarm threshold adjustable around dew point upper alarm threshold:	34 °F to 45 °F, factory setting 37 °F
lower alarm threshold:	30 °F to 27 °F, factory setting 27 °F
Dew point fluctuations static:	±0.2 K (with stainless steel), ±0.5 K (with PVDF), ±0.5 K (with glass)
in the entire specification range:	± 2 K
Type of protection electric	IP 54
Housing	Stainless steel/Polyester
Weight incl. heat exchanger	approx. 82 lb
Electric supply	115 V or 230 V, 50/60 Hz, terminals
Power input	250 VA (230 V) or 300 VA (115 V)
Protection:	Protective motor switch (breaking capacity 1.5 kA or higher) 115 V version: 3.2 A 230 V version: 1.3 A
Status output fuse:	Breaking capacity 1.5 kA or higher. Dimensioned per the status contact switching capacity and customer application (see type examination certificate, item 15.3.1.2).
Potential-free alarm output ("fail safe")	230 V / 3 A AC 115 V / 3 A AC 24 V / 1 A DC
Installation	Stand-alone or wall-mounted
Packaging dimensions:	27.6 x 20.5 x 20.5 in, on pallet (dimensions: 31.5 x 23.6)

Description

The flashing display and the status relays indicate the conditions are below or above the configured warning range (e.g. after switching on). If the cooler is stopped or in the event of service, an error code will appear.

Dimensions

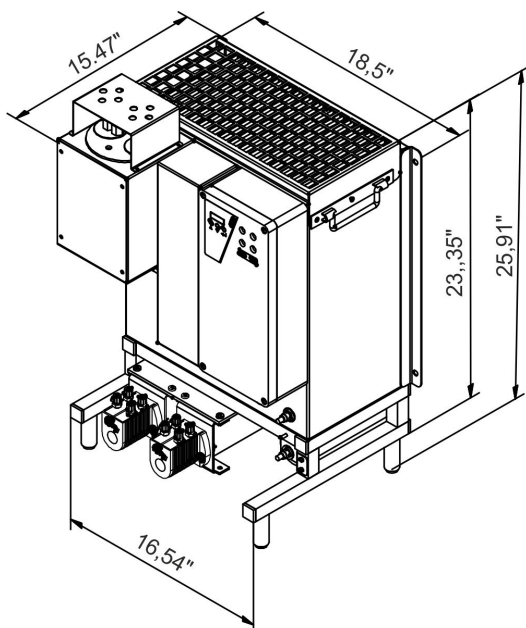

Mounting holes

17.5 x 16.5 x Ø0.4 (wide x high x diameter)

Performance data

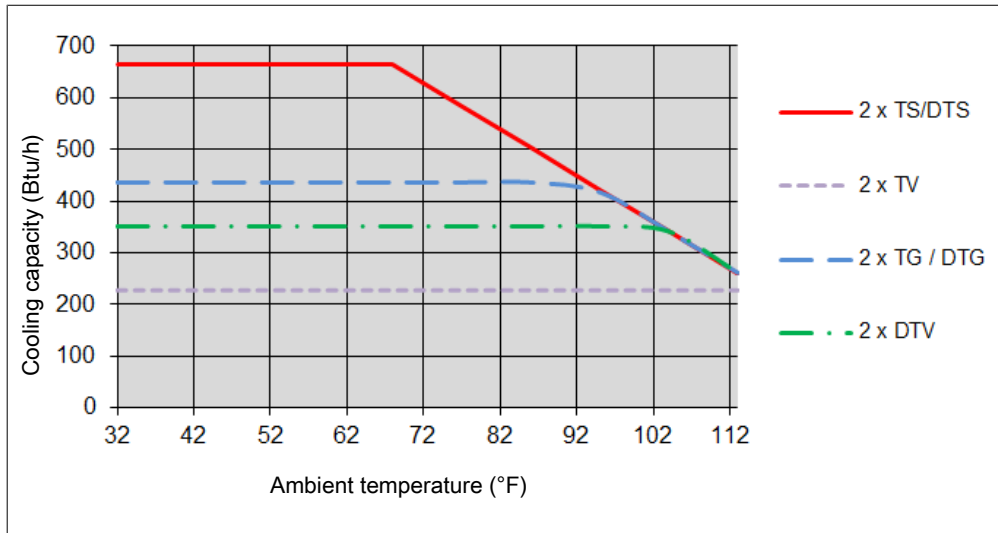

Note: The limit curves for the heat exchangers exchanger apply to a dew point of 149 °F.

Heat exchanger description

The energy content of the sample gas and the required cooling capacity of the gas cooler is determined by three parameters: gas temperature ϑ_G , (inlet) dew point τ_e (moisture content) and volume flow v . The outlet dew point rises with increasing energy content of the gas. The approved energy load from the gas is therefore determined by the tolerated rise in the dew point.

The following limits are specified for a normal standard operating point of $\tau_e = 149$ °F and $\vartheta_G = 194$ °F. The maximum volume flow v_{max} in NI/h of cooled air is indicated, so after moisture has condensed.

If the values fall below τ_e and ϑ_G , the flow v_{max} may be increased. For example, on the TG heat exchanger the parameter triple $\tau_e = 149$ °F, $\vartheta_G = 194$ °F and $v = 4.7$ lpm may also be used in place of $\tau_e = 122$ °F, $\vartheta_G = 176$ °F and $v = 6.3$ lpm.

Please contact our experts for clarification or refer to our design program.

Heat exchanger overview

Heat exchanger	TS TS-I ²⁾	TG TG	TV-SS TV-SS-I ²⁾	DTS (DTS-6 ³⁾) DTS-I (DTS-6-I ³⁾) ²⁾	DTG DTG	DTV ³⁾ DTV-I ²⁾³⁾
Version/Material	Stainless steel	Glass	PVDF	Stainless steel	Glass	PVDF
Flow v_{max} ¹⁾	8.8 lpm	4.7 lpm	2.1 lpm	2 x 4.2 lpm	2 x 2.3 lpm	2 x 1.9 lpm
Inlet dew point $\tau_{e,max}$ ¹⁾	176 °F	176 °F	149 °F	176 °F	149 °F	149 °F
Gas inlet temperature $\vartheta_{G,max}$	266 °F (356 °F) ⁵⁾	266 °F	266 °F	266 °F (356 °F) ⁵⁾	266 °F	266 °F
Max. cooling capacity Q_{max}	427 Btu/h	218 Btu/h	114 Btu/h	427 Btu/h	218 Btu/h	175 Btu/h
Gas pressure p_{max}	2321 psi	44 psi	44 psi	363 psi	44 psi	29 psi
Pressure drop Δp ($v=2.5$ lpm)	0.12 psi	0.12 psi	0.12 psi	0.07 psi each	0.07 psi each	0.22 psi each
Dead volume V_{tot}	4.2 cu. in.	2.9 cu. in.	7.9 cu. in.	1.7/1.5 cu. in	1.7/1.5 cu. in	1.3/1.3 cu. in
Gas connections (metric)	G1/4" i	GL 14 (6 mm) ⁴⁾	DN 4/6	6 mm tube	GL14 (6 mm) ⁴⁾	DN 4/6
Gas connections (US)	NPT 1/4" i	GL 14 (1/4") ⁴⁾	1/4"-1/6"	1/4" tube	GL14 (1/4") ⁴⁾	1/4"-1/6"
Condensate out connection (metric)	G3/8" i	GL 25 (12 mm) ⁴⁾	G3/8" i	Tube 10 mm (6 mm)	GL18 (10 mm) ⁴⁾	DN 5/8
Condensate out connection (US)	NPT 3/8" i	GL 25 (1/2") ⁴⁾	NPT 3/8" i	Tube 3/8" (1/4")	GL18 (3/8") ⁴⁾	3/16"-5/16"

¹⁾ Max. cooling capacity of the cooler must be considered.

²⁾ Models marked I have NPT threads or US tubes, respectively.

³⁾ Condensate drain only possible with condensate pump

⁴⁾ Gasket inside diameter

⁵⁾ With temperature class T3 gases the permissible gas inlet temperature is max. 356 °F.

Ordering instructions

The item number is a code for the configuration of your unit. Please use the following model key:

Please note: Every individual gas path must be equipped with condensate drain.

4590	X	X	X	X	X	X	X	X	1	Product characteristics (metric connections)
										Voltage ¹⁾
1										115 V
2										230 V
										Gas path/material/version
0	0	0								without heat exchanger
										1 gas path/material/version
1	1	0								1x single heat exchanger/stainless steel/TS
1	2	0								1x single heat exchanger/glass/TG
1	3	0								1x single heat exchanger/PVDF/TV
										2 gas paths/material/version
2	1	0								2x single heat exchanger/stainless steel/TS
2	2	0								2x single heat exchanger/glass/TG
2	3	0								2x single heat exchanger/PVDF/TV
2	6	0								1x dual heat exchanger/stainless steel/DTS (10 mm)
2	6	1								1x dual heat exchanger/stainless steel/DTS-6
2	7	0								1x dual heat exchanger/glass/DTG
2	8	0								1x dual heat exchanger/PVDF/DTV ²⁾
										3 gas paths/material/version
3	1	0								1x single heat exchanger + 1x dual heat exchanger/stainless steel/TS+DTS (10 mm)
3	1	1								1x single heat exchanger + 1x dual heat exchanger/stainless steel/TS+DTS-6
3	2	0								1x single heat exchanger + 1x dual heat exchanger/glass/TG+DTG
3	3	0								1x single heat exchanger + 1x dual heat exchanger/PVDF/TV+DTV ²⁾
										4 gas paths/material/version
4	6	0								2x dual heat exchanger/stainless steel/DTS (10 mm)
4	6	1								2x dual heat exchanger/stainless steel/DTS-6
4	7	0								2x dual heat exchanger/glass/DTG
4	8	0								2x dual heat exchanger/PVDF/DTV ²⁾
										Condensate drain
	0	0	0							without condensate drain
										1 gas path
1	1	1								1x peristaltic pump CPsingle with adapter ³⁾
1	1	3								1x peristaltic pump CPsingle with screw connection ³⁾
3	0	0								1x AK20 installed ³⁾
4	0	0								1x 11 LD V38 installed
										2 gas paths
1	2	2								1x peristaltic pump CPdouble with adapter ³⁾
1	2	4								1x peristaltic pump CPdouble with screw connection ³⁾
3	0	0								2x AK20 installed ³⁾
4	0	0								2x 11 LD V38 installed
										3 gas paths
1	3	2								1x peristaltic pump CPdouble + 1x peristaltic pump CPsingle with adapter ³⁾
1	3	4								1x peristaltic pump CPdouble + 1x peristaltic pump CPsingle with screw connection ³⁾
3	0	0								3x AK20 installed ³⁾
4	0	0								3x 11 LD V38 installed
										4 gas paths
1	4	2								2x peristaltic pump CPdouble with adapter ³⁾
1	4	4								2x peristaltic pump CPdouble with screw connection ³⁾
3	0	0								4x AK20 installed ³⁾
4	0	0								4x 11 LD V38 installed

4590	X	X	X	X	X	X	X	X	1	Product characteristics (US connections)
										Voltage ¹⁾
1										115 V
2										230 V
										Gas path/material/version
0	0	0								without heat exchanger
										1 gas path/material/version
1	1	5								1x single heat exchanger/stainless steel/TS-I
1	2	5								1x single heat exchanger/glass/TG-I
1	3	5								1x single heat exchanger/PVDF/TV-I
										2 gas paths/material/version
2	1	5								2x single heat exchanger/stainless steel/TS-I
2	2	5								2x single heat exchanger/glass/TG-I
2	3	5								2x single heat exchanger/PVDF/TV-I
2	6	5								1x dual heat exchanger/stainless steel/DTS-I (3/8")
2	6	6								1x dual heat exchanger/stainless steel/DTS-6-I
2	7	5								1x dual heat exchanger/glass/DTG-I
2	8	5								1x dual heat exchanger/PVDF/DTV-I ²⁾
										3 gas paths/material/version
3	1	5								1x single heat exchanger + 1x dual heat exchanger/stainless steel/TS+DTS-I (3/8")
3	1	6								1x single heat exchanger + 1x dual heat exchanger/stainless steel/TS+DTS-6-I
3	2	5								1x single heat exchanger + 1x dual heat exchanger/glass/TG+DTG-I
3	3	5								1x single heat exchanger + 1x dual heat exchanger/PVDF/TV-I+DTV-I ²⁾
										4 gas paths/material/version
4	6	5								2x dual heat exchanger/stainless steel/DTS-I (3/8")
4	6	6								2x dual heat exchanger/stainless steel/DTS-6-I
4	7	5								2x dual heat exchanger/glass/DTG-I
4	8	5								2x dual heat exchanger/PVDF/DTV-I ²⁾
										Condensate drain
0	0	0								without condensate drain
										1 gas path
1	1	1								1x peristaltic pump CPsingle with adapter ³⁾
1	1	3								1x peristaltic pump CPsingle with screw connection ³⁾
3	0	0								1x AK20 installed ³⁾
4	0	0								1x 11 LD V38 installed
										2 gas paths
1	2	2								1x peristaltic pump CPdouble with adapter ³⁾
1	2	4								1x peristaltic pump CPdouble with screw connection ³⁾
3	0	0								2x AK20 installed ³⁾
4	0	0								2x 11 LD V38 installed
										3 gas paths
1	3	2								1x peristaltic pump CPdouble + 1x peristaltic pump CPsingle with adapter ³⁾
1	3	4								1x peristaltic pump CPdouble + 1x peristaltic pump CPsingle with screw connection ³⁾
3	0	0								3x AK20 installed ³⁾
4	0	0								3x 11 LD V38 installed
										4 gas paths
1	4	2								2x peristaltic pump CPdouble with adapter ³⁾
1	4	4								2x peristaltic pump CPdouble with screw connection ³⁾
3	0	0								4x AK20 installed ³⁾
4	0	0								4x 11 LD V38 installed

¹⁾ Cooler operation inside Ex area only permitted with suitable protective motor switch.

²⁾ Operation with condensate drains and traps not available.

³⁾ This option limits the approved application of the complete cooler to gas group IIB.

Spare Parts and Accessories

Item no.	Description
91 320 200 09	Protective motor switch for installation outside Ex area 230 V, 50/60 Hz
91 320 200 29	Protective motor switch for installation outside Ex area 115 V, 50/60 Hz
91 320 200 32	Protective motor switch for installation inside Ex area 230 V, 50/60 Hz
91 320 200 35	Protective motor switch for installation inside Ex area 115 V, 50/60 Hz
91 100 000 78	Microfuse 125 mA, interrupt rating 1500 A
91 200 201 39	Relay 24 VDC, 2 changeover contacts
91 200 201 43	Relay 230 VAC, 2 changeover contacts
91 460 303 14	Fuse clip
44 10 00 5	Condensate trap GL 1; glass, 0.4 L
44 10 01 9	Condensate trap GL 2; glass, 1 L
45 09 99 19	Mounting kit for peristaltic pump X1
44 92 00 35 011	Norprene replacement hose with straight connections for peristaltic pump 0.005 lpm
44 92 00 35 014	Norprene replacement hose with screw connection DN 4/6 for peristaltic pump 0.005 lpm